

QUALITY STONE VENEER, INC. **CLIP SYSTEM™** **INSTALLATION GUIDE**

HOW TO INSTALL QUALITY STONE VENEER'S *LAMBRIS* PRODUCT LINE INCLUDING CLIP SYSTEM AND DIRECT APPLICATION PROCEDURES.

INSTALLATION METHODS COVERED:

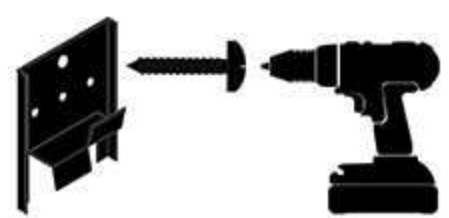

THE QUALITY STONE VENEER PATENTED **CLIP SYSTEM™** APPLICATION



DIRECT APPLICATION

QUALITY STONE VENEER'S LAMBRIS PRODUCT LINE:

APILADA, SEGOVIA
 DRYSTACK LAMBRIS, OHIO DRYSTACK LAMBRIS
 COBBLESTONE LAMBRIS, FIELDSTONE LAMBRIS
 URBANA FUSION, URBANA TRAVERTINE
 METROPOLITAN BRICK, HISTORIC BRICK
 PIEDRA CORTADA, SIOTA BLOCK



www.QualityStoneVeneer.com



Quality Stone Veneer, Inc.
 50 Refton Road
 Refton, PA 17568
 United States

(800) 795-3229

VIDEO



Scan to watch a video training series corresponding to this manual.



QUALITY STONE VENEER, INC.

CLIP SYSTEMTM INSTALLATION GUIDE

TABLE OF CONTENTS

COMPANY INTRODUCTION |

PAGE 1

FOREWORD, CLIP SYSTEM VS. DIRECT APPLICATION |

PAGE 2

LAMBRIS STONE, BLOCK & THIN BRICK STYLES |

PAGE 3

GENERAL PRODUCT INFORMATION & SYSTEM REQUIREMENTS |

PAGE 4

PERSONAL PROTECTIVE EQUIPMENT, SAFETY INSPECTION |

PAGE 5

REQUIRED TOOLS, CUTTING STATION SETUP |

PAGE 6 - 7

ESTIMATING STONE PIECE COUNTS & PRODUCT DIMENSIONS |

PAGE 8 - 9

RECOMMENDED FRAMING DIMENSIONS FOR STONE COLUMNS |

PAGE 10 - 11

DETERMINING THE INSTALLATION METHOD FOR YOUR WALL TYPE |

PAGE 12

TABLE OF CONTENTS

CLIP SYSTEM ADVANTAGES |

PAGE 12

CLIP SYSTEM INSTALLATION MATERIALS |

PAGE 13

MATERIAL CLEARANCES AND TERMINATION DETAILS |

PAGE 14

CLIP SYSTEM PREPARATION & UNDERLAYMENT |

PAGE 15 - 19

CLIP SYSTEM PRODUCT INSTALLATION |

PAGE 20 - 24

DIRECT APPLICATION PREPARATION & UNDERLAYMENT |

PAGE 25 - 28

DIRECT APPLICATION PRODUCT INSTALLATION |

PAGE 29 - 33

FINAL PRODUCT GROUTING & FINISHING PROCEDURES |

PAGE 34 - 35

CLIP SYSTEM WINDOW PREPARATION & UNDERLAYMENT |

PAGE 36 - 37

DETAIL QSV-31.0 : CLIP SYSTEM AT KNEEWALL |

PAGE 38

DETAIL QSV-32.0 : CLIP STARTER STRIP AT FOUNDATION |

PAGE 39

DETAIL QSV-33.0 : CLIP SYSTEM AT TOP OF WINDOW |

PAGE 40

DETAIL QSV-34.0 : CLIP SYSTEM FLOOR TO FLOOR TRANSITION |

PAGE 41

DETAIL QSV-35.0 : STUD WALL TO FOUNDATION WALL TRANSITION | PAGE 42

DETAIL QSV-36.0 : CLIP SYSTEM AT SIDE OF WINDOW |

PAGE 43

LAMBRIS PRODUCT LINE COLOR SELECTIONS & MORTAR PAIRING |

PAGE 44



WHO ARE WE?

- Company Introduction
- Core Values
- Areas of Service
- Turnkey Packages
- Material Only Packages
- Contact



SINCE 1976

Founded in 1976, Quality Stone Veneer has been committed to producing and installing the most durable and aesthetic stone veneer product in the world. Our molds replicate the shapes and textures of natural stone. A process involving a hand cast-

ing of actual natural stone, intricate detail is achieved in a vast variation of pieces, leaving no two individual stones looking exactly alike. The end result is an unmatched natural aesthetic.

Quality, Sustainability, Value, Innovation.

QUALITY

Quality Stone Veneer, Inc. is constantly striving to provide a quality product, intricately detailed installation, and excellent customer service, approaching each project with commitment, diligence, and attention to detail.

SUSTAINABILITY

We strive to be stewards of resources, aligning our operations with both the business and the natural environment. We wisely invest and allocate our finances and time, enabling the company to be profitable and influential to our local economies.

VALUE

Considering employees are our most valuable assets, we provide jobs with opportunities for advancement in an environment that allows everyone to be safe and productive.

INNOVATION

Our employees are encouraged to think creatively and pursue curiosity, creating new avenues for the company to grow and excel in our industry.

AREAS OF SERVICE

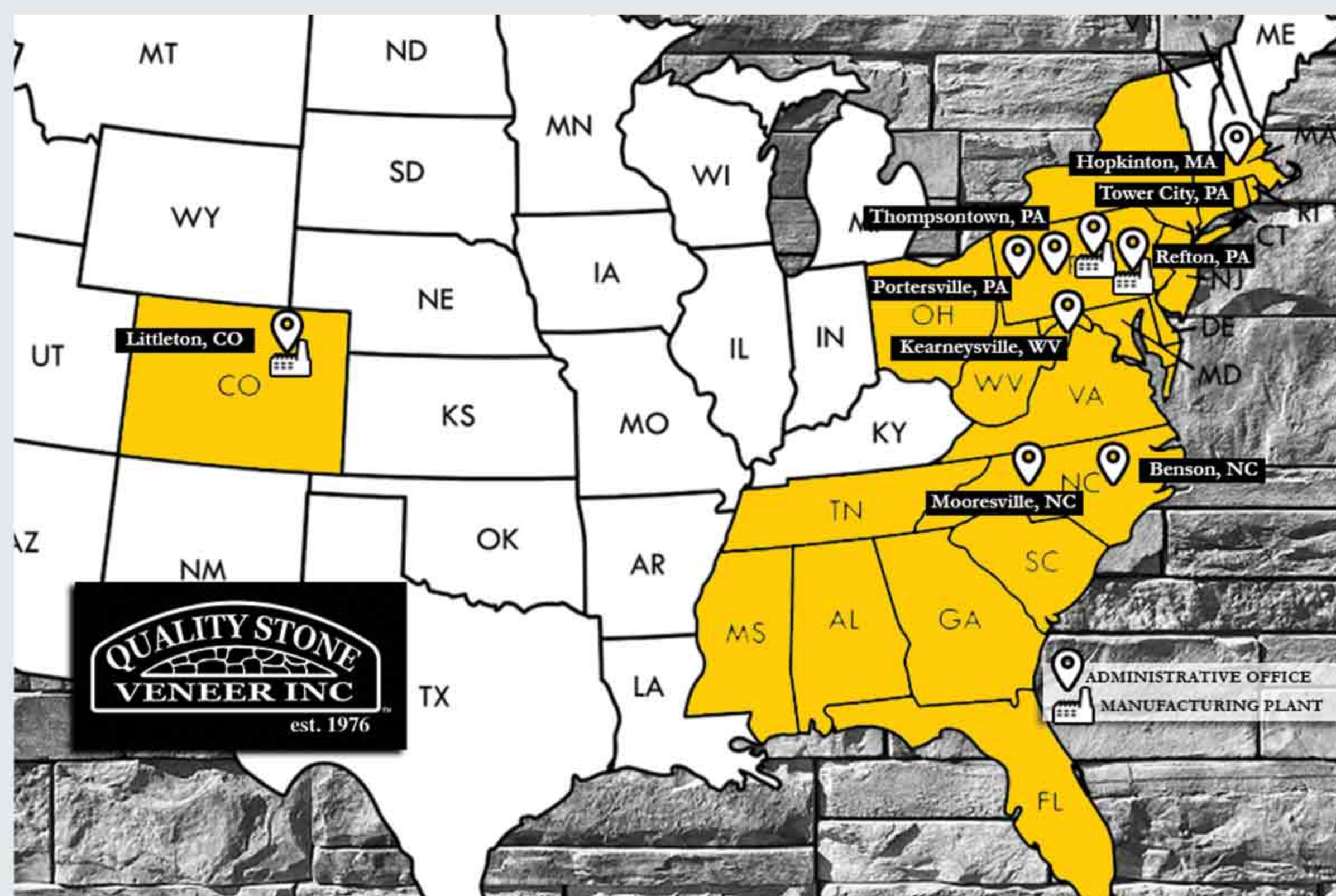

Our Footprint

Quality Stone Veneer started in 1976 in Refton, Pennsylvania where we're still headquartered today. In fact, in all those 40-some years, our corporate address and phone number have remained the same.

Quality Stone Veneer has since expanded up and down the east coast and out to Colorado. We proudly service all markets within these territories, both in turnkey material and installation packages, and in product only sales.

Our products are designed for all types of building construction, residential and commercial, interior and exterior, regardless of the scope or size of the project.

Whether you're building a dream home, remodeling an existing home, adding stone to a fireplace, building a church, university, hotel, apartment building, or an assisted living facility, we bring your ideas to life from concept to completion.

FULL TURNKEY PACKAGES



1

MATERIAL ONLY PACKAGES



2

1) Turnkey Material + Installation Packages

Quality Stone Veneer specializes in both the manufacturing of the stone and its installation. We can provide a full turnkey package from project estimation, delivery to site, installation and site management, to final product. A single source of accountability from project inception to completion ensures your project is done right, everytime.

2) Material Only Packages

Product Only packages are also available. QSV can supply everything from preparation and installation materials, hand crafted precast, to any stone style and color combination you can dream of.

DIRECTORY

Orders, Technical Services, Warranty

(717) 786-3229

Samples and Literature

info@qualitystoneveneer.com

CLIP SYSTEM INSTALLATION GUIDE

FOREWORD

This Installation Guide has been produced to help builders, masons, architects and installers alike in the preparation and installation of Quality Stone Veneer's line of **Lambris** stone, block and thin brick styles. Reviewed in this guide is a detailed look at how the Lambris product line is paired with the Quality Stone Veneer Patented **Clip System™** application method. An installation method designed with moisture management in mind, the **Clip System™** allows for a more-easily installed, better functioning stone veneer system, with a built-in drainage plane behind the stone.

Also discussed in this guide is the traditional mortar and wire lath, or **Direct Application** method, to be followed when the substrate the Lambris product is being installed over is better suited for this method, such as a CMU block wall or concrete

foundation. This manual must be read in conjunction with the project's drawings and specifications, applicable building codes, and relevant compliance documents. The details within this manual provide guidance on how to comply with Quality Stone Veneer's installation requirements for all Lambris styles, both in Clip System and Direct Application installations.

These requirements and best practices should be reviewed and followed by all parties who are responsible for installing Quality Stone Veneer products on a project in order for warranty to apply.

This manual is subject to periodic re-examination and revision at any time. For information on the current status of these documents please consult your local QSV representative.

INSTALLATION METHODS DEFINED

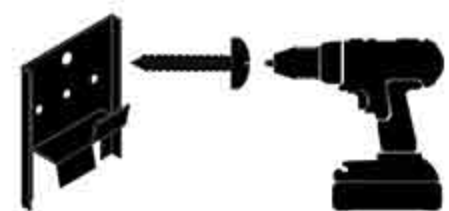

THE QUALITY STONE VENEER PATENTED **CLIP SYSTEM™** APPLICATION

INSTALLATION

COMPONENTS

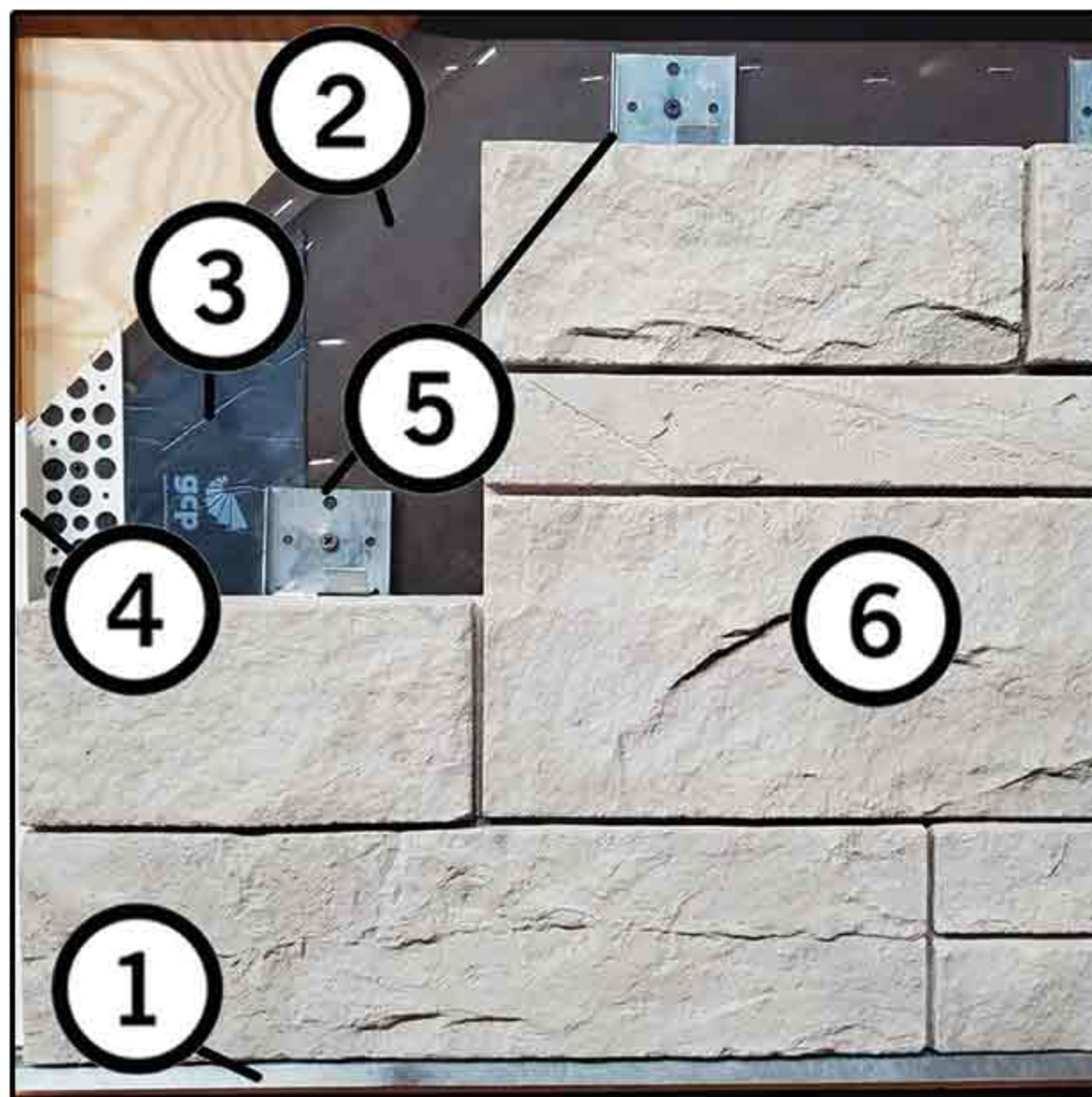

- 1 Clip Starter Strip
- 2 60-Minute WRB
- 3 Self-adhered Rubber Flashing
- 4 Casing Bead with built-in backer rod
- 5 Clip & Screw
1/4" Built-In Drainage Plane
- 6 Lambris Stone Selection



DIRECT APPLICATION

INSTALLATION

COMPONENTS

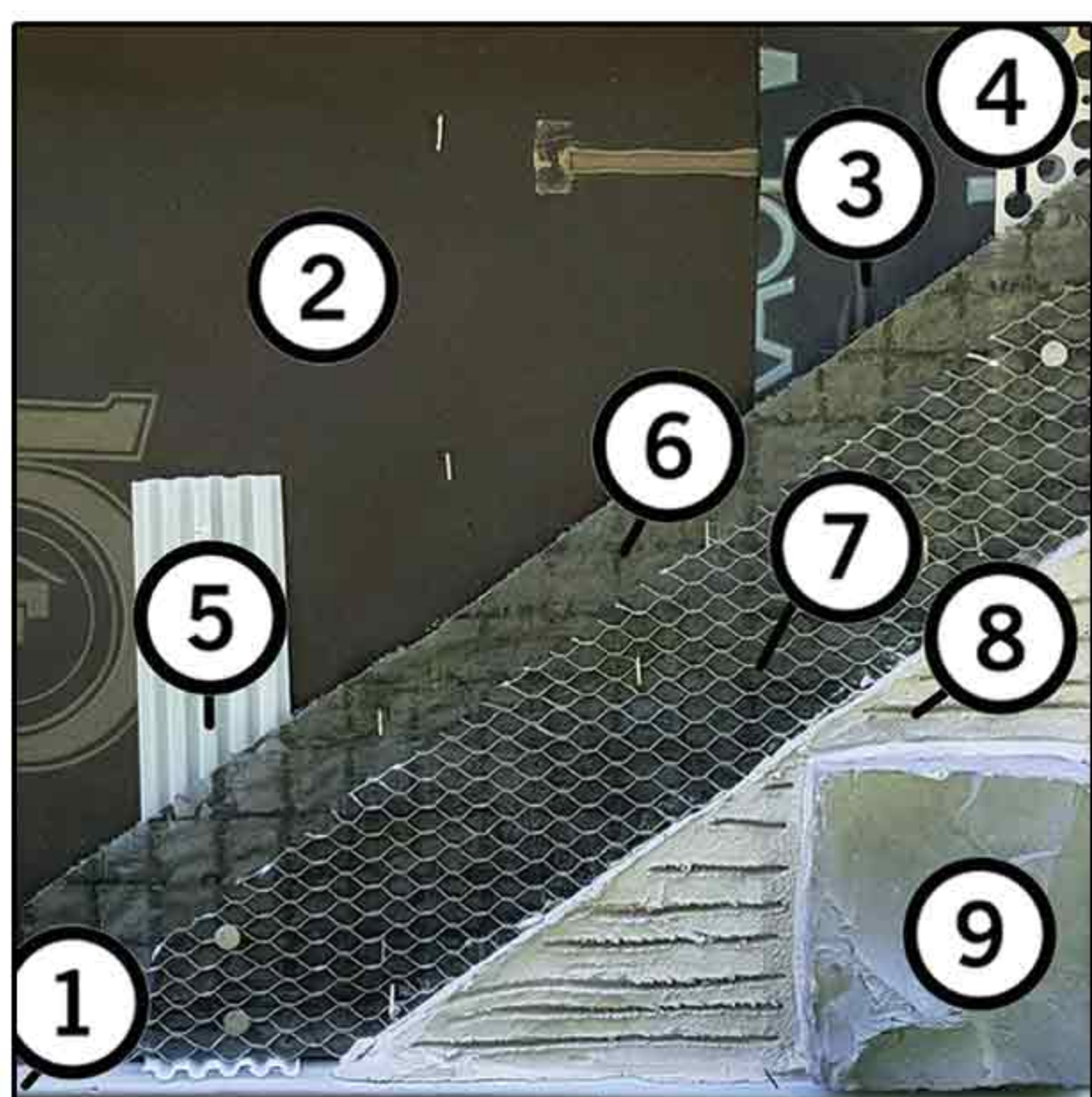

- 1 Drip Cap
- 2 60-Minute WRB
- 3 Self-adhered Rubber Flashing
- 7 Wire Lath
- 9 Lambris Stone Selection
- 4 Casing Bead with built-in backer rod
- 5 Wall Opening Weeps
- 6 Drain Mat
1/4" Drainage Plane
- 8 Mortar Scratch Coat

APPLICABLE STONE STYLES

QUALITY STONE VENEER'S LAMBRIS PRODUCT LINE



 DRYSTACK LAMBRIS

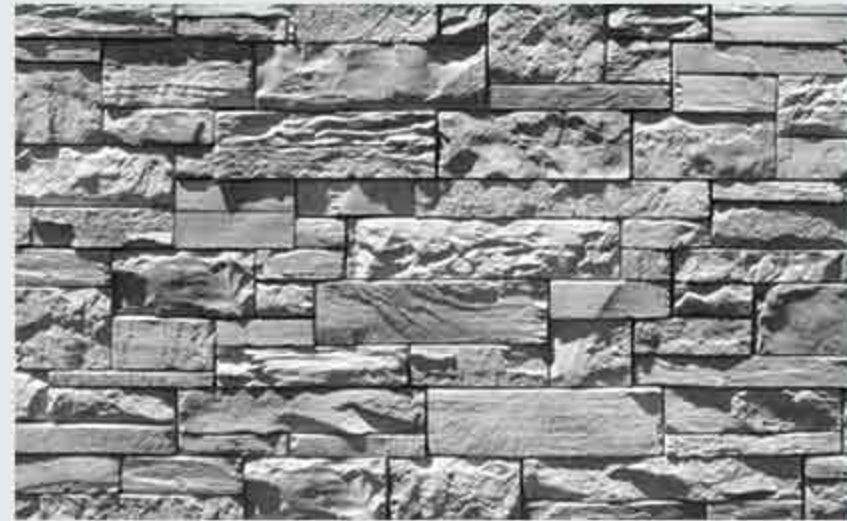

 OHIO DRYSTACK LAMBRIS



 URBANA FUSION



 URBANA TRAVERTINE

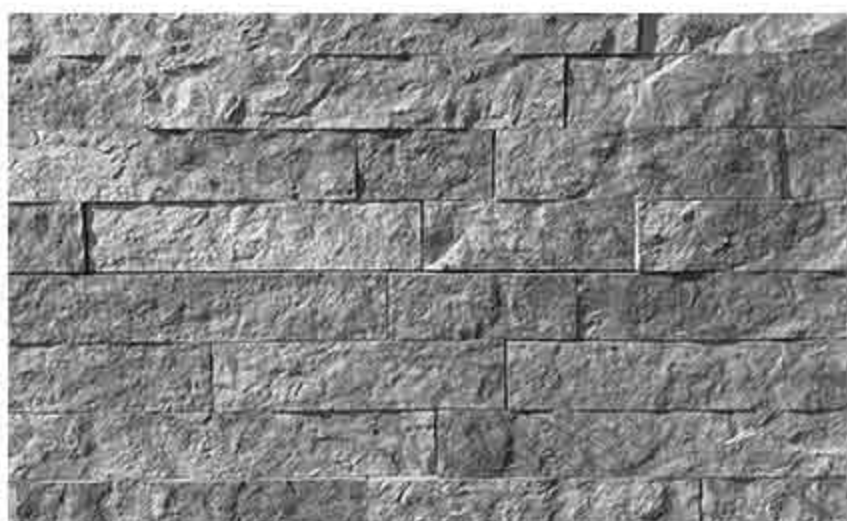

 APILADA

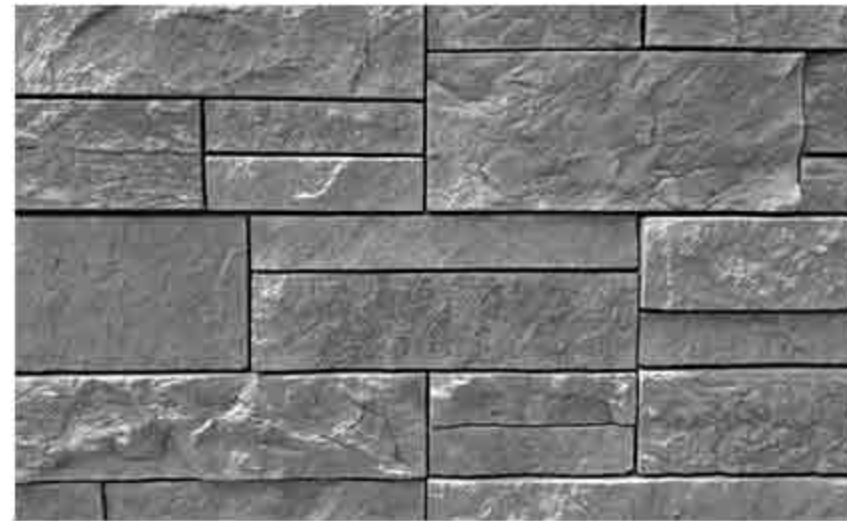

 SEGOVIA



 METROPOLITAN BRICK



 HISTORIC BRICK



 COBBLESTONE LAMBRIS



 FIELDSTONE LAMBRIS

DRYSTACK

URBANA

MODERN

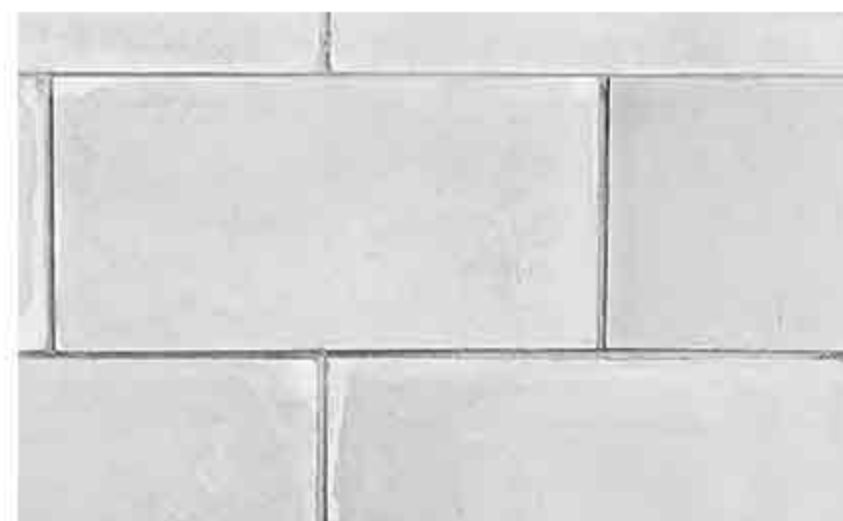

 PIEDRA CORTADA



 SIOTA BLOCK

THIN BRICK & BLOCK

COBBLE & FIELD

Note: All Lambris styles are pictured in black and white. For a full look at color ranges and color options compatible with each style, please visit our website or contact your local QSV representative. Colorways per style along with mortar pairings are also listed on page 44.

GENERAL PRODUCT INFORMATION

SYSTEM REQUIREMENTS

GENERAL PRODUCT INFORMATION

STORAGE AND HANDLING

QSV products should be stored in unopened packaging until ready for installation to prevent damage from moisture, temperature, or outside forces. Cementitious materials should be stored on elevated platforms, under cover, and in a dry location. Do not use cementitious materials that have become damp.

MAINTENANCE

Most applications require no maintenance. The use of a high quality waterproofing sealer is recommended on any Quality Stone Veneer surface, but especially on those exposed to severe freezing or thawing, excessive moisture, or conditions which could discolor or stain the stone. A sealed surface is much easier to clean than an unsealed surface.

Power washing the face of the stone can be damaging to the stone and mortar and is therefore not recommended.

A high pressure blower, such as a leaf-blower, can be used as a final face cleaning to the stone in outdoor areas.

EFFLORESCENCE

Efflorescence is normal and common in all masonry products and easily remedied. To remove, allow stone to dry. Scrub with stiff bristle brush and clean water. If efflorescence is still noticeable, scrub with a solution of 50% household white vinegar and 50% water and rinse thoroughly. Do not power wash stone. Do not use any salt and calcium chloride products on areas adjacent to stone veneer product.

SYSTEM REQUIREMENTS

WEATHERPROOFING & UNDERLAYMENT

All waterproofing and underlayment in stone areas including water resistive barrier, flashing and trim are to be coordinated with construction of studs, soffits, and other adjoining work to provide a secure and water-tight installation.

For an up to date look at national code requirements for all weatherproofing and underlayment for stone veneer installations, please visit NCMA.org to download the latest version of the National Concrete Masonry Association's stone veneer installation guideline.

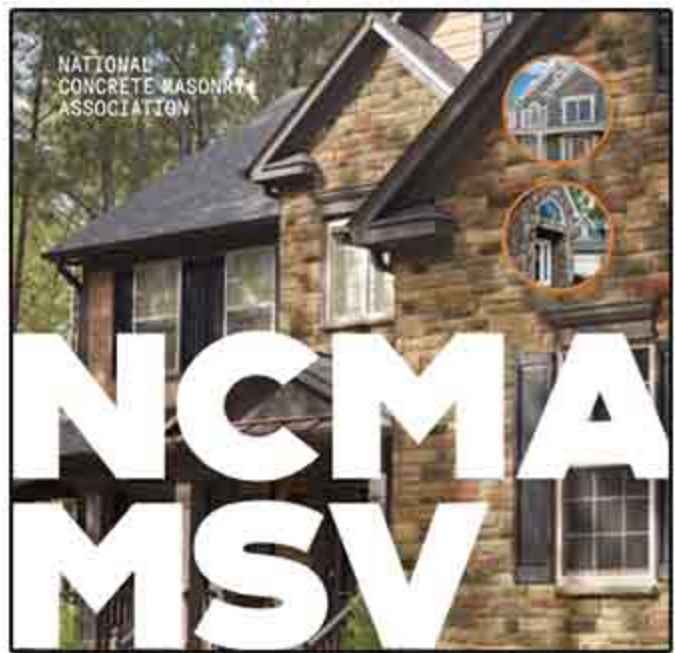

SUBSTRATE REQUIREMENTS

Installation of stone panels requires a substrate capable of supporting a load of 20 pounds per square foot minimum for a Clip System Application, and 25 pounds per square foot for Direct Application. Areas of rigid insulation will require a layer of plywood over the rigid insulation in order to meet this load requirement.

CLIP SYSTEM SPECIFIC INSTALLATION REQUIREMENTS

The Quality Stone Veneer, Inc. Clip System application requires a plywood substrate to accept the galvanized Clips and Screws, hitting studs where possible.

DESIGN DEFLECTION

For all products, including cast accessories, a minimum building Design Deflection of L/360 is required. A Design Deflection of L/600 is recommended.

GENERAL INSTALLATION REQUIREMENTS

Outside temperatures must exceed 40 Degrees F for all mortared applications to allow for proper mortar bond and curing. Morar scratch coat must cure for 24 hours before stone installation can begin.

MATERIAL STAGING

Stage and pull from multiple boxes throughout the entirety of the stone installation to create a consistent blend of color and texture on the wall.

GAPPING TO DISSIMILAR MATERIALS

Stone is required to terminate 3/8" minimum from dissimilar materials and openings to allow for expansion and contraction. Failure to do so can result in material cracking due to a building's thermal movement.

ONE MANUFACTURER. ONE INSTALLER. ONE SOURCE OF ACCOUNTABILITY.



PERSONAL PROTECTIVE EQUIPMENT

INSTALLING SAFELY

“WE CHOOSE SAFETY FIRST.”



REQUIRED PPE

-







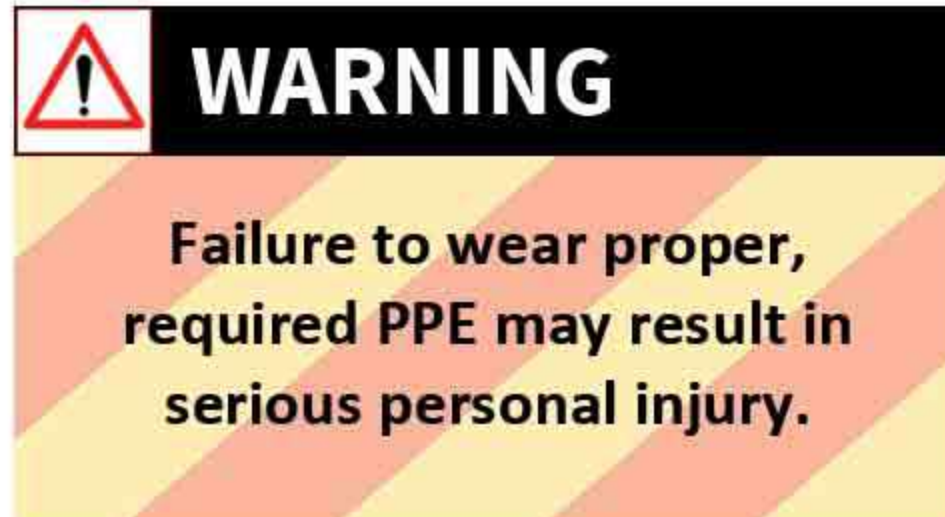

Quality Stone Veneer has compiled a list of required personal protective equipment for use in the preparation and installation of any stone veneer system.

OSHA:

Refer to OSHA.gov for all up to date jobsite safety codes and requirements.

OSHA 
COMPLIANT



PPE	PHOTO	AREA OF USE
Hard Hat		Head Protection
Steel Toe Boots		Foot Protection
Hi-Vis Safety Vest		Or similar to make it easier for drivers to spot workers in construction zones.
Safety Glasses		Eye protection during cutting and installation.
Dust Mask/Respirator		Respiratory protection while cutting.
Protective Gloves		Hand Protection
Hearing Protection		Used when noise is over 85 decibels. Used while any cutting takes place.
Long Pants		Leg Protection
Fall Protection		Fall protection equipment when working above 6 feet.

PRE-INSTALLATION JOBSITE SAFETY INSPECTION

-

Safety is always first priority while working on any jobsite. Use a checklist such as the one here to inspect your work area before installation or work of any kind begins. What Pre-Installation steps do you need to take before beginning to ensure the safety of all workers throughout the entirety of the project?

For all information on jobsite safety requirements and best practices, please visit OSHA.gov.

JOBSITE SAFETY CHECKLIST	YES	NO	N/A
Work areas free from overhead work?			
Workspace protected from immediate jobsite hazards?			
All workers wearing proper personal protective equipment?			
Caution tape in place for pedestrian traffic?			
All workers trained and certified to use equipment on site?			
Fire extinguisher & first aid kit available on the jobsite?			
Electric cords free from defects?			
Unserviceable hand tools tagged for repair?			
All guards on cutting blades?			
Emergency contact information available on site?			
Updated SDS Binder on site?			



















Scan to visit www.qualitystoneveneer.com









REQUIRED TOOLS

CUTTING, MEASUREMENT, INSTALLATION & FINISHING TOOLS

TOOL	PHOTO	AREA OF USE
Cutting and Power Tools		
Compound Miter Saw with Dust Collection		Cutting stone panels. Saws should be used in conjunction with a vacuum equipped with a HEPA filter for maximum dust protection. Cutting should take place in an outdoor, well-ventilated area.
Angle Grinder with Guard		Small adjustment cutting and notching of stone panels.
Masonry Specific Blades for Saw and Grinder		Cutting and notching stone panels when required.
Power Drill		Clip System Clip and Starter Strip installation.
Fastener Gun		Fastening wire lath and flashing materials in direct applied installations, most common over cement or block areas.
Measurement and Accuracy		
Tape Measure		Measurement
Square (Various)		Accuracy in cutting
Level (Various)		Leveling of installation of flashing, stone panels, etc. Checking existing transitions for levelness.
String Line and Line Blocks		Lines and Blocks are to be used vertically at all outside corners and horizontally at each row of stone to ensure levelness.
Surface Preparation		
Tin Snips		Cutting of wire lath and flashings
Razor Knife		Cutting and opening installation materials
Hammer Tacker		WRB Installation
Rubber Mallet		Subtle tapping of stone panels to lock them in place.
Mortar Preparation and Finishing Tools		
Mixing Bucket, Concrete Mixer, or Wheelbarrow		Mortar Mixing
Mixing Paddle		Used in conjunction with a power drill for a consistent, even mortar mix.
Darby		Leveling of mortar scratch coat in Direct Applications.
Grout Bag		Jointing of stone panels, caps and accessories where required.

REQUIRED TOOLS CONTINUED

CUTTING STATION SETUP

TOOL	PHOTO	AREA OF USE
Mortar Preparation and Finishing Tools		
Trowel (Various)		Mortar Application
Joint Slicking Tool (Various)		Raking mortar joints between products where required.
Brush (Various)		Stone finishing and final clean up
Surface Protection and Clean Up		
Quality Stone Veneer Finishing Kit		Used on touch up areas and on exposed cut ends of stone. One pint of stain figured per 500 sq/ft, or 1 quart per 1,000 sq/ft.
Painters Tape, Plastic, Tarps, Paper, Cardboard, or similar		Covering of all surface areas for protection during stone installations. Including, but not limited to, windows, floors, flatwork, transitions and trim.
Power Blower		Final face cleaning of stone. To be used in outside, well-ventilated areas only, down-wind of other workers.

CUTTING STATION SETUP

Stone cutting station should be set up in a well-ventilated, outdoor area where dust particles can be carried away from workers. An approved respirator should be used at all times while cutting, in addition to hearing and eye protection. Never cut stone indoors where dust particles can become airborne and trapped.

Cut stone panels face down to minimize the amount of dust that collects on the face of the product. This reduces clean up during final finishing stages of the install.

CLEAN UP

Clean up of dust and debris is best completed using a vacuum with a HEPA filter, especially in indoor and non-ventilated areas.



WARNING: AVOID BREATHING SILICA DUST

Quality Stone Veneer products contain respirable crystalline silica. Crystalline silica is a common mineral found in the earth's crust. Materials like sand, stone, concrete, and mortar contain crystalline silica, and are used to make products such as ceramics, brick, and artificial stone veneer. Activities related to the installation of stone veneer, such as cutting, grinding, or breaking, may result in the release of respirable silica found in the dust. Breathing excessive amounts of respirable silica dust can cause damage to lungs through prolonged or repeated inhalation exposure, and can also lead to a potentially fatal lung disease called silicosis. During cutting, handling, and installation: (1) work in well-ventilated areas; (2) use a circular saw with vacuum attachment and HEPA filter to reduce dust while cutting (3) warn others in the immediate area; (4) wear a properly fitted approved dust mask or respirator in accordance with applicable government regulations and current manufacturer instructions to further limit respirable silica exposure. In addition, do not eat, drink or smoke while handling product. Protective gloves, clothing, eye and face protection should be used at all times. Wash from skin with plenty of water. Never cut stone indoors. For further information, refer to current OSHA procedures and regulations by visiting www.OSHA.gov, or by calling 1-800-795-3229 to speak to a Quality Stone Veneer Safety representative.

LAMBRIS STONE, THIN-BRICK, AND BLOCK DIMENSIONS

DETERMINING PIECE COUNTS OF LAMBRIS PRODUCTS

A quantity of each stone piece required for a project is calculated by taking the stone square footage, or lineal footage of corner areas, divided by the individual footage each piece covers, shown below. A higher percentage of the largest flat size is recommended in wide open wall areas. A blend of small and large flat sizes are recommended in smaller, more intricate wall sections to

reduce cutting. Quality Stone Veneer's team of estimating experts are available to help determine a recommended Lambris piece count calculated from the project's total stone square footage you provide. Contact us today to get started, whether your project requires our material only, or our material + installation.

APILADA

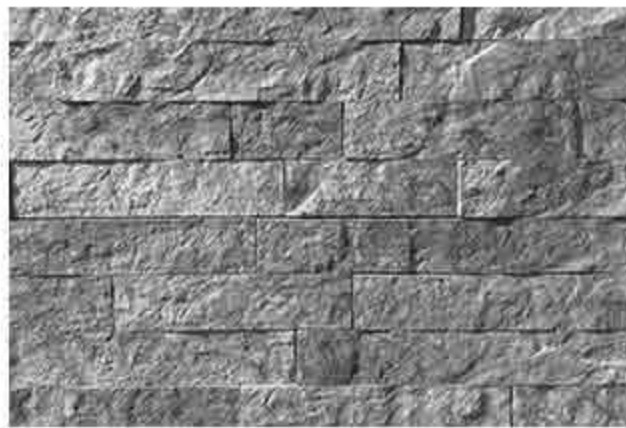

SEGOVIA

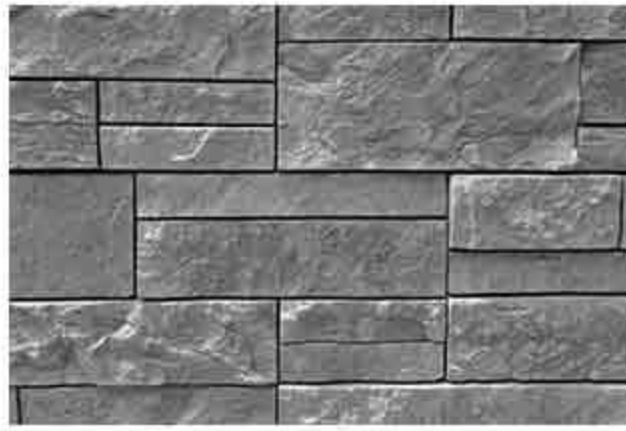

APILADA		
PIECE	DIMENSION	SQUARE FOOTAGE
	26 $\frac{3}{4}$ "x12"x1 $\frac{1}{2}$ " Flat	2.22
	26 $\frac{3}{4}$ "x3"x1 $\frac{1}{2}$ " Flat	0.55
	16 $\frac{1}{2}$ "x6"x1 $\frac{1}{2}$ " Corner	0.68

SEGOVIA		
PIECE	DIMENSION	SQUARE FOOTAGE
	24"x16"x1 $\frac{1}{2}$ " Flat	2.66
	24"x8"x1 $\frac{1}{2}$ " Flat	1.33
	24"x8"x1 $\frac{1}{2}$ " Corner	1.33
	16"x8"x1 $\frac{1}{2}$ " Corner	0.88

OHIO DRYSTACK LAMBRIS



DRYSTACK LAMBRIS



OHIO DRYSTACK LAMBRIS		
PIECE	DIMENSION	SQUARE FOOTAGE
	24"x12"x1 $\frac{1}{2}$ " Flat	2
	24"x4"x1 $\frac{1}{2}$ " Flat	0.67
	24"x12"x1 $\frac{1}{2}$ " Corner	2
	16 $\frac{1}{4}$ "x12"x1 $\frac{1}{2}$ " Corner	1.35

DRYSTACK LAMBRIS		
PIECE	DIMENSION	SQUARE FOOTAGE
	18"x12"x1 $\frac{3}{4}$ " Flat	1.5
	18"x6"x1 $\frac{3}{4}$ " Flat	0.75
	18"x6"x1 $\frac{3}{4}$ " Corner	0.75
	12"x6"x1 $\frac{3}{4}$ " Corner	0.5

URBANA FUSION



URBANA TRAVERTINE



URBANA FUSION		
PIECE	DIMENSION	SQUARE FOOTAGE
	24"x16"x1 $\frac{3}{4}$ " Flat	2.66
	24"x8"x1 $\frac{3}{4}$ " Flat	1.33
	24"x8"x1 $\frac{3}{4}$ " Corner	1.33
	16"x8"x1 $\frac{3}{4}$ " Corner	0.88

URBANA TRAVERTINE		
PIECE	DIMENSION	SQUARE FOOTAGE
	24"x16"x1 $\frac{3}{4}$ " Flat	2.66
	24"x8"x1 $\frac{3}{4}$ " Flat	1.33
	24"x8"x1 $\frac{3}{4}$ " Corner	1.33
	16"x8"x1 $\frac{3}{4}$ " Corner	0.88

LAMBRIS STONE, THIN-BRICK, AND BLOCK DIMENSIONS





DETERMINING PIECE COUNTS OF LAMBRIS PRODUCTS





COBBLESTONE LAMBRIS



FIELDSTONE LAMBRIS



COBBLESTONE LAMBRIS		
PIECE	DIMENSION	SQUARE FOOTAGE
	24"x16"x1 3/4" Flat	2.66
	24"x8"x1 3/4" Flat	1.33
	24"x8"x1 3/4" Corner	1.33
	16"x8"x1 3/4" Corner	0.88

FIELDSTONE LAMBRIS		
PIECE	DIMENSION	SQUARE FOOTAGE
	28 1/2"x16"x1 3/4" Flat	2.92
	28 1/2"x8"x1 3/4" Flat	1.46
	18 1/4"x8"x1 3/4" Flat	0.77
	8"x 4 3/4"x1 3/4" Flat	0.27
	22 1/2"x16"x 1 3/4" Corner	2.25

DESIGNATED PATTERN

The designated pattern for the Lambris style being installed should be followed to maintain the proper breaking up of horizontal and vertical joints.

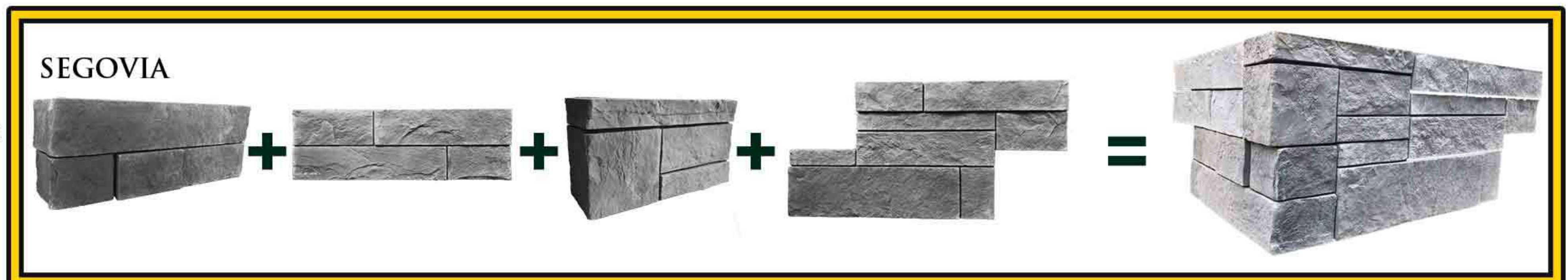







METROPOLITAN BRICK



HISTORIC BRICK



METROPOLITAN BRICK		
PIECE	DIMENSION	SQUARE FOOTAGE
	8"x15 3/4"x1 1/2" 6B Flat	0.87
	8"x 2 5/8" x1 1/2" 1B Flat	0.14
	16 3/4"x5 1/4"x1 1/2" Corner	0.61

HISTORIC BRICK		
PIECE	DIMENSION	SQUARE FOOTAGE
	26"x12"x1 1/2" 12B Flat	2.16
	8 3/4"x15"x1 1/2" 5B Flat	0.91
	8 3/4"x6"x 1 1/2" 2B Flat	0.36
	17 1/2"x6"x1 1/2" Corner	0.72



PIEDRA CORTADA



SIOTA BLOCK



PIEDRA CORTADA		
PIECE	DIMENSION	SQUARE FOOTAGE
	24"x12"x1 3/4" Flat	2
	24"x3"x1 3/4" Flat	0.5
	20"x12"x1 3/4" Corner	1.66

SIOTA BLOCK		
PIECE	DIMENSION	SQUARE FOOTAGE
	48"x8"x1 1/2" 3B Flat	2.66
	16"x8"x1 1/2" 1B Flat	0.88
	20"x8"x1 1/2" Corner	1.11

STONE COLUMNS

RECOMMENDED FRAMING DIMENSIONS FOR COLUMNS

APILADA



FRAMING DIMENSIONS:

- A. 15.25" x 15.25"
- B. 42.25" x 15.25"

SEGOVIA



- A. 23.25" x 23.25"
- B. 15.25" x 15.25"

DRystack
LAMBRIS

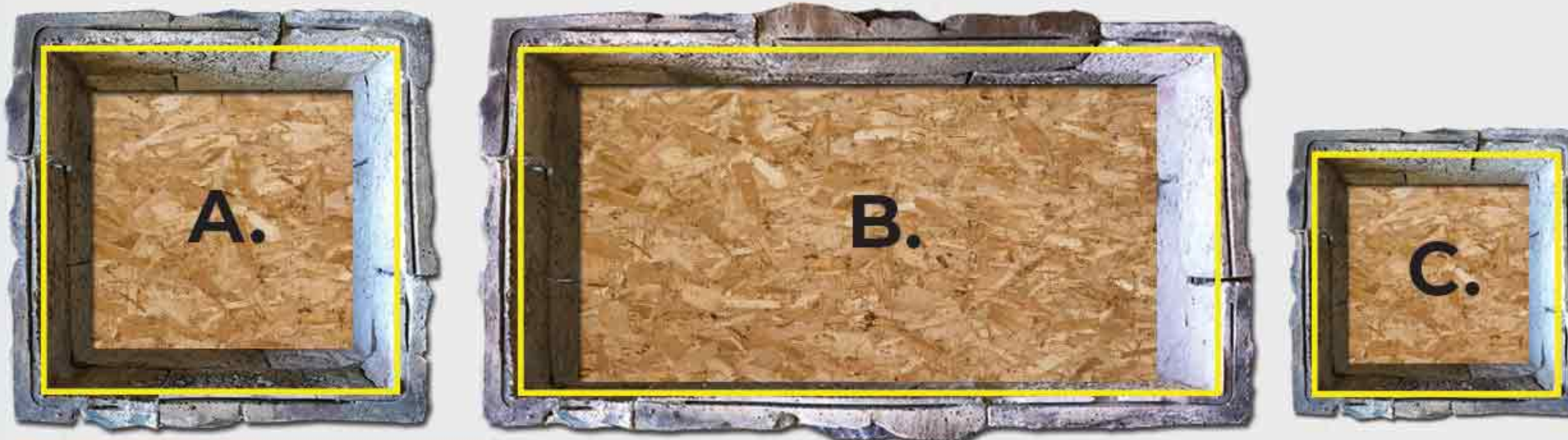

- A. 17.25" x 17.25"
- B. 34.75" x 17.25"
- C. 11.25" x 11.25"

OHIO
DRystack
LAMBRIS

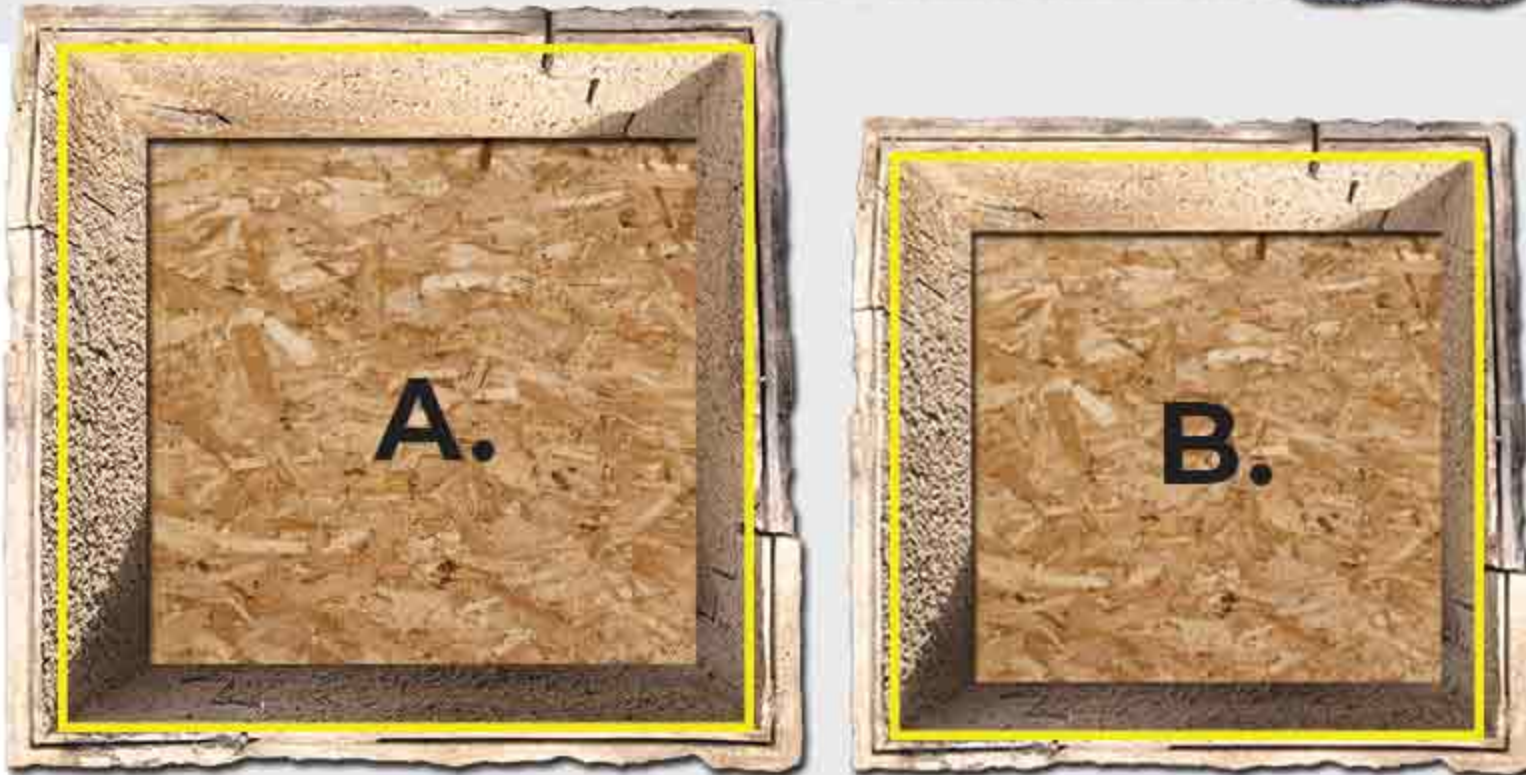

- A. 23.75" x 23.75"
- B. 15.75" x 15.75"

URBANA
FUSION
URBANA
TRAVERTINE



- A. 23.25" x 23.25"
- B. 15.25" x 15.25"
- C. 39.75" x 15.25"

COLUMN INSTALLATION

Planning ahead with pre-selected column framing dimensions paired specifically for the Lambris style you're using can drastically minimize cutting and installation time and create a seamless fit of perfectly interlocked pieces.

Stone Style: Ohio Drystack Lambris
Stone Color: *Provence*
Installation Method: Clip System™

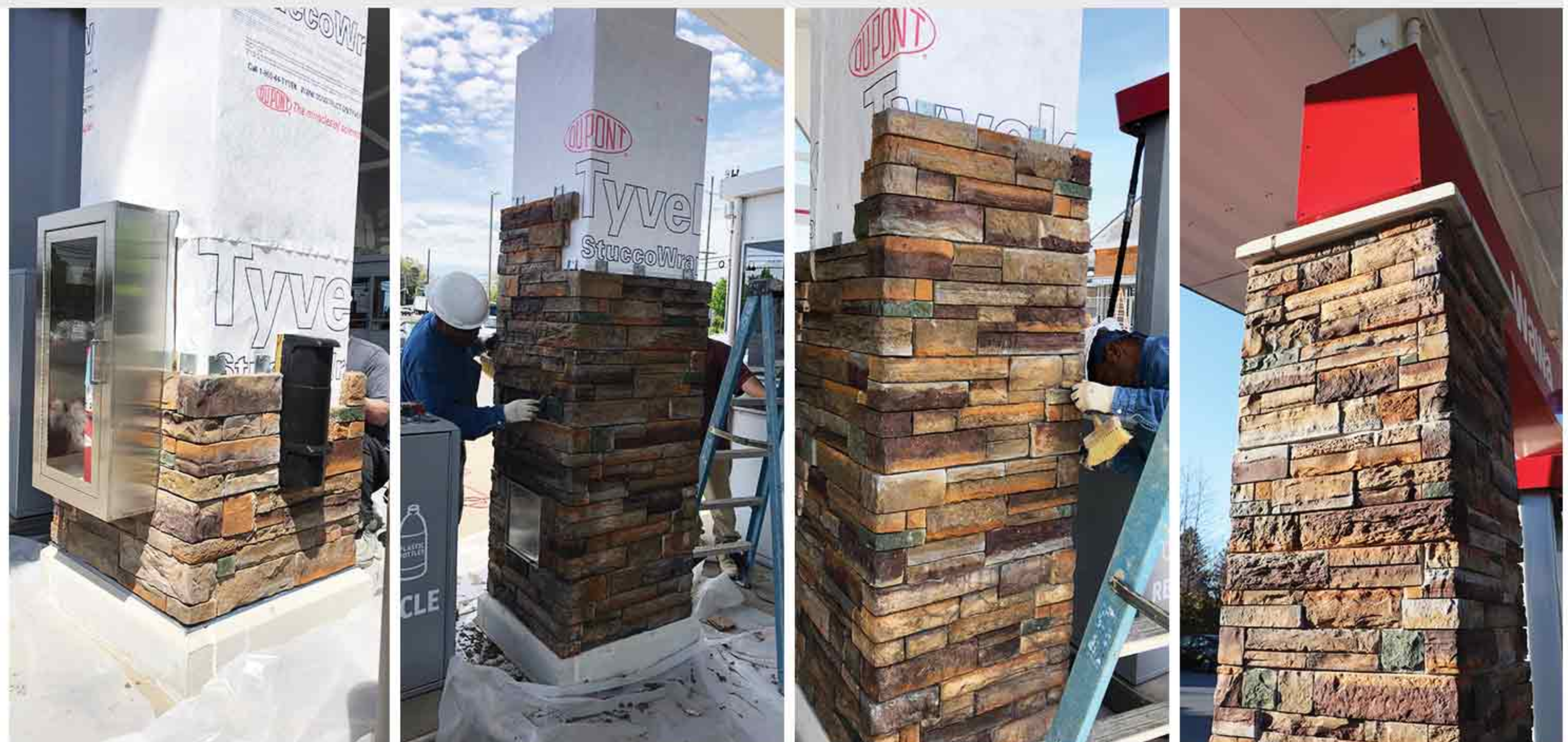

STONE COLUMNS

RECOMMENDED FRAMING DIMENSIONS FOR COLUMNS CONTINUED

COBBLESTONE
LAMBRIS



FRAMING DIMENSIONS:

A. 15.75"x15.75"
B. 23.75"x23.75"

METROPOLITAN
BRICK



A. 16.25"x16.25"
B. 16.25"x40.25"

HISTORIC
BRICK



A. 16.5"x16.5"

PIEDRA
CORTADA



A. 19.5"x19.5"

SIOTA
BLOCK



A. 19.75"x19.75"
B. 19.75"x36"

COLUMN INSTALLATION

Whether a Clip System install or Direct Application install, framing dimensions allow for enough space for either the Clip and Screw attachment, or wire lath & mortar scratch coat.



INSTALLATION

SELECTING THE INSTALLATION METHOD BEST-SUITED FOR YOUR WALL TYPE

Before getting started, first determine which installation method is most suitable for your project. The Clip System is most commonly installed over stud framed wall systems requiring an exterior plywood substrate to accept the Clips and Screws, hitting studs where possible. A Direct Application (traditional mortar and wire installation) is primarily used when the stone panels are to be installed over concrete areas including concrete foundations, CMU block walls and retaining walls. Although, some framed wall types may also be better fastened to using this installation method. These wall types

are, but not limited to: areas of rigid insulation, or gypsum sheathing areas. For all up to date Direct Application material requirements, installation codes and procedures, refer to the National Concrete Masonry Association's latest edition of the **NCMA Installation Guide** by visiting www.NCMA.org. All Quality Stone Veneer installations, both Clip System and Direct Application, follow all guidelines and specifications set forth by this guide. Any deviation from these set standards will void Quality Stone Veneer's limited warranty. Always consult local building codes before getting started with your project.

Wall Type

- Wooden (OSB) Stud framed wall with exterior plywood sheathing
 - Steel Stud framed wall with exterior plywood sheathing
 - Rigid insulation with exterior plywood sheathing
- *Wall type rated to support 20 lbs per sq/ft minimum

INSTALLATION METHOD:



CLIP SYSTEM

PAGE 15

Wall Type

- CMU Block wall
 - Concrete Foundation wall
 - Concrete Retaining wall
 - Rigid insulation (without exterior plywood sheathing)
 - Gypsum sheathing, or similar
- *Wall type rated to support 25 lbs per sq/ft minimum

INSTALLATION METHOD:



DIRECT APPLICATION

PAGE 25

CLIP SYSTEM ADVANTAGES

WHAT SOLUTIONS DOES A CLIP SYSTEM INSTALLATION PROVIDE?



BUILT-IN DRAINAGE

Designed for moisture management, a ¼" air space between the wall and stone allows moisture to drain freely.



LESS WEIGHT

Less weight to install and requires no structural cement.



FEWER WEATHER LIMITATIONS

Can be installed in conditions sub 40 degrees F where a mortar and wire application require heating and tenting.



EASE OF INSTALLATION

Installs more easily than a mortar and wire, direct application.



REDUCTION ON MATERIALS

Eliminates the need for most cement, wire lath, drain mats, and casing beads.



TIME SAVINGS

Can save a considerable amount of time on installation and finishing.



CONTROLLED PATTERN

Preset stone panels with varying shapes and an off-setting pattern provide a control over the install, eliminating any guesswork in laying.



EASIER REMODELS

Remodel and transform an existing project more easily and more cost effectively.



PROFILE COMBINATIONS

Stone styles can be combined to create a building diverse in masonry type and color.



CLEAN FINISH EDGES

Precise finish edges can be cut where stone meets dissimilar materials, such as at window and door frames.



NATURAL AESTHETIC

Stone profiles are hand cast from natural stone, leaving no two faces of stone looking exactly alike.



VERSATILITY











Stone panels have the ability to be direct applied with mortar and wire lath when required, such as transitioning stone onto a concrete foundation.

CLIP SYSTEM INSTALLATION

INSTALLATION MATERIALS

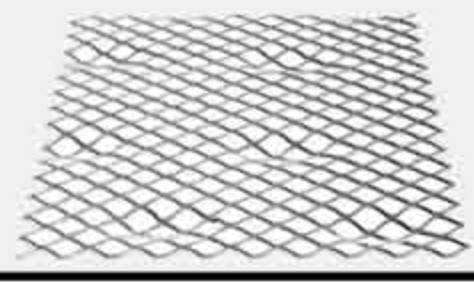
CLIP SYSTEM INSTALLATION MATERIAL REQUIREMENTS

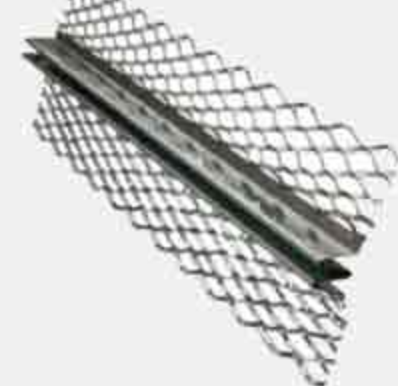
The following installation materials are required on all Quality Stone Veneer Clip System™ installations. For technical support on installation materials, contact 1-800-795-3229, or info@qualitystoneveneer.com to speak with a representative.

CLIP SYSTEM INSTALLATION MATERIAL	PHOTO	AREA OF USE
Water Resistive Barrier		Secondary layer of WRB is figured for the entire square footage of the stone area. WRB is to comply with ASTM D226, ASTM E2556, or equivalent.
6" Self-Adhered Rubber Flashing		Self-Adhered Flashing (6" Flexible Flashing Tape) is figured at and around all dissimilar materials in stone areas, including but not limited to, MEP penetrations, windows, doors and vertical transitions. An additional run of Self-Adhered Flashing is used when stone continues from the stud wall down onto concrete foundation.
Ice and Water Shield		Ice and Water Shield waterproof underlayment membrane is to be used on top of framed columns, CMU masonry columns and walls alike, to cap and seal the top of the structure from water intrusion.
Clip Starter Strip		22 gauge galvanized metal Clip Starter Strip is used at the base of stud walls as a weep screed flashing over the sill plate transition. Used above windows, doors and framed openings as a drip cap flashing. Used at horizontal floor to floor transitions as a expansion joint at rim joist level as stone continues up the wall. Clip Starter Strips are 10' long per piece.
Clip		20 gauge galvanized metal Clips used to fasten stone panels to the wall system. Minimum of 2 Clips per square foot of stone required. To calculate total Clips required, take the stone square footage x 2.3, then subtract the required linear footage of Clip Starter Strip from this number.
Clip Screw		1 5/8" Phillips-head galvanized metal Clip Screw used in fastening metal Clips and Clip Starter Strip to the wall. 1 Clip Screw is to be included per Clip, and 1 per linear foot of Clip Starter Strip required. There are 127 Clip Screws per pound.
Casing Bead with factory applied backer rod		2" Vinyl Casing Bead with factory applied backer rod, or similar flashing approved by Quality Stone Veneer. Used at all 4 sides of windows, doors, openings and vertical transitions to dissimilar materials to provide a 3/8" gap for expansion and contraction that can be caulked. Available in 10' lengths.
Wire Lath		1 piece of Wire Lath per 500 square feet of stone installed is to be figured. Used in conjunction with mortar to install precast accessory items, such as sills and light blocks often subject to fixture attachment and contact.
Drain Mat		Or, "rain screen" is required behind the wire lath in areas where products are direct applied over a plywood substrate in order to maintain a consistent drainage plane.
Expansion Joint		Galvanized zinc finish control and expansion joints are required to provide for movement, and to accommodate expansion and contraction caused by initial wall shrinkage and minor thermal movement. Installed at changes in wall heights, adjacent to changes in materials, and alongside windows and doors where possible. Spacing not to exceed 15 foot on center in any direction. Produced in galvanized steel and zinc alloy in 10' lengths.
Polymer Modified Mortar		Used in conjunction with wire lath in the attachment of precast stone accessories, including sills, light, and outlet blocks subject to fixture attachment and contact. To be compliant with ANSI A118.4 or ANSI A118.5. 1 bag of Polymer Modified Mortar is to be figured per 200 square feet of Clip System stone areas.
Quality Stone Veneer Finishing Kit		Finishing kit designed for stone touch up areas and on exposed cut ends of stone. 1 pint of stain figured per 500 sq/ft, or 1 quart per 1,000 sq/ft.

CLIP SYSTEM INSTALLATION

MATERIAL CLEARANCES

FIG. 1: UNDERLAYMENT AT WINDOW

Vinyl casing bead with factory-applied backer rod is to be used at all 4 sides of windows, doors and vertical transitions to dissimilar materials in stone areas. This practice provides a 3/8" gap allowing for expansion and contraction that can then be caulked.

* See note below on window flashings.

FIG. 2: CLIP STARTER STRIP ABOVE WINDOW AND DOOR HEADS

Clip Starter Strip is to be installed immediately over the casing bead to maintain a 3/8" gap to the window, or door head.

FIG. 3: GAPPING UNDER WINDOW

Vinyl casing bead under windows provides a 3/8" gap between the precast sill, or stone, to the base of the window frame.

FIG. 4: EXPANSION JOINT LOCATIONS

Install galvanized expansion joints at changes in wall heights, adjacent to changes in materials and at windows and doors where possible, as a continuation of the break the vertical casing bead creates at the side of the opening. Spacing not to exceed 15 foot on center in any direction.

VERTICAL EXPANSIONS:



HORIZONTAL EXPANSIONS:



Detail: Page 41

FIG. 5: GAPPING TO DISSIMILAR MATERIAL LOCATIONS

Always maintain a 3/8" gap in stone areas at:

- Windows, doors and framed openings
- Transitions to siding or dissimilar material
- Stone to stone inside corners
- MEP Penetrations and similar openings
- Expansion Joint locations
- All protrusions

FIG. 6: IMPROPER GAPPING TO DISSIMILAR MATERIALS

WARNING

Failure to gap stone to dissimilar materials may result in cracking due to building thermal movement and settling.

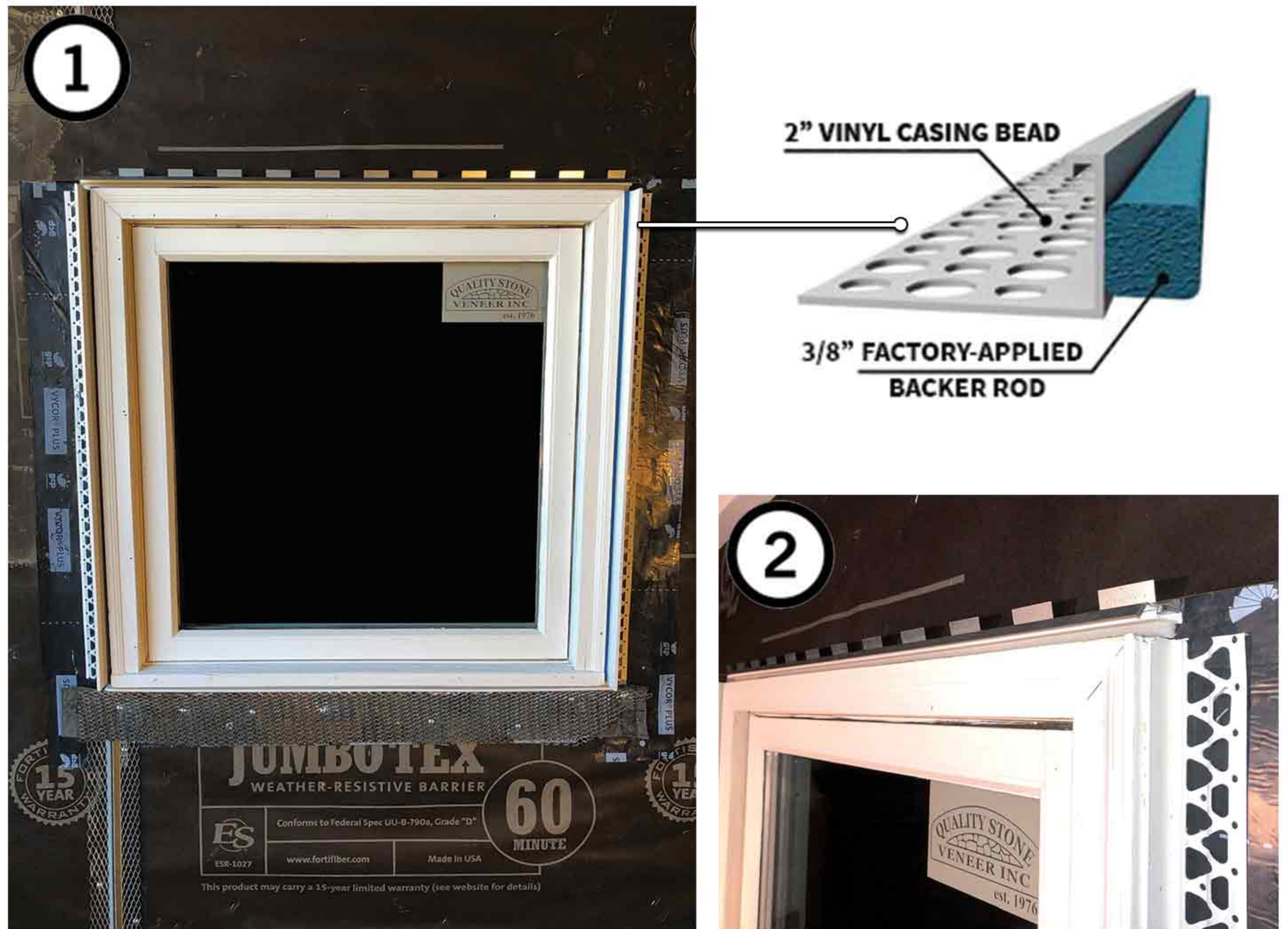

WINDOW FLASHINGS

Detail under window will depend on the window type. Windows should be flashed per the window manufacturer's recommendation. Follow all local code requirements.

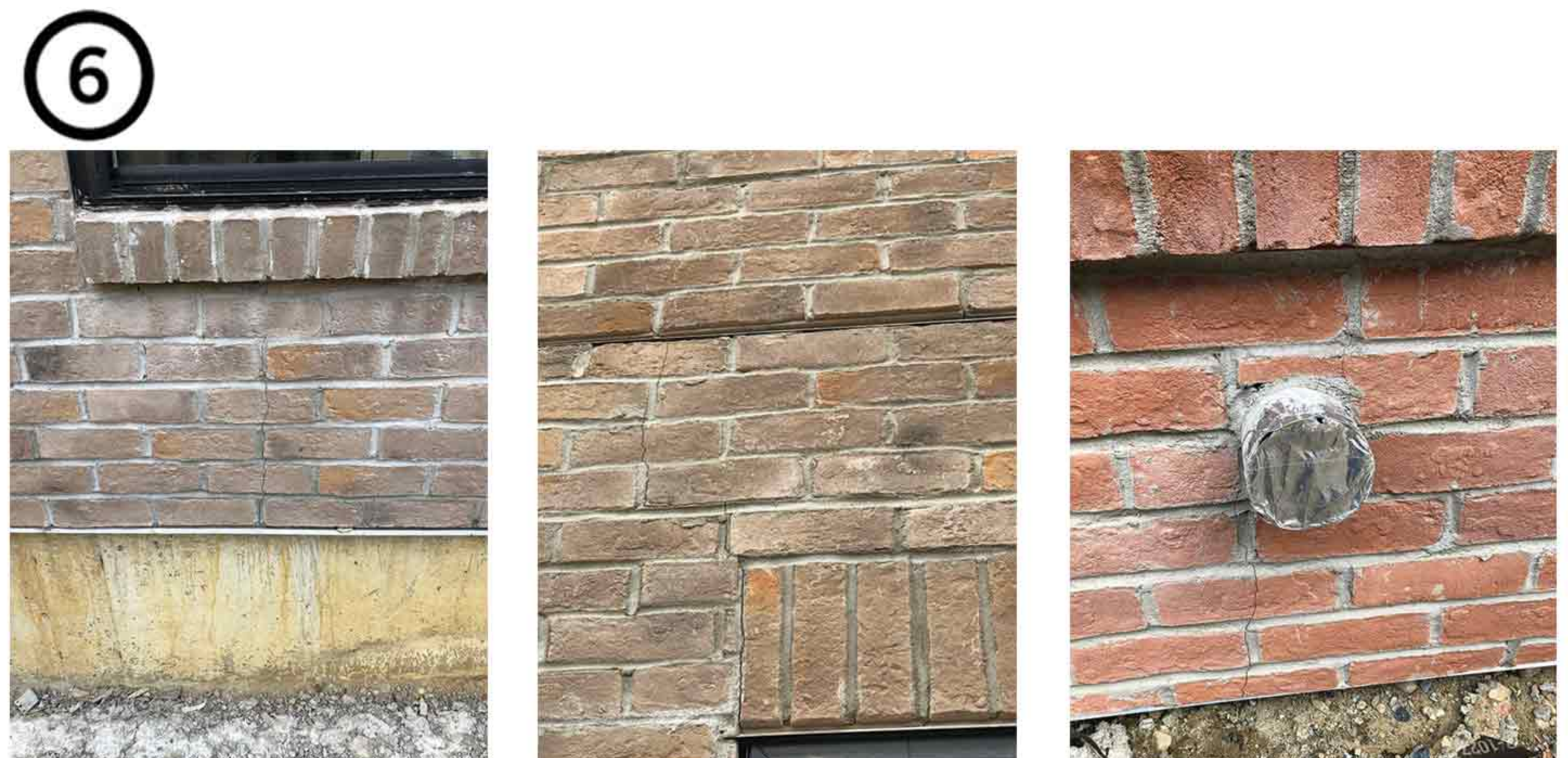

CLIP SYSTEM INSTALLATION

PREPARING THE WALL FOR A CLIP SYSTEM INSTALLATION

1. Jobsite Safety Inspection

Before beginning any work on site, verify workspace is safe and free from all hazards. Use a jobsite safety inspection checklist like the one shown on page 5 of this guide. All workers should be equipped with the proper personal protective equipment for the job.

“We Choose Safety First.”

2. Check Stone Termination Points and Flatwork

Ensure all necessary terminations, flashings, penetrations and trim pieces are present to have a designated termination point for stonework in each direction. Concrete flatwork below stone area should be in place before stone installation, to have a clear understanding of where to properly stop stone at the base of the wall.



3. Protection of Existing Materials

Begin by protecting existing finished surface areas. Install plastic covering around windows, doors, trim, siding, and any additional protrusions in stone areas using painters tape. Cover and protect any finished surfaces below stone areas with cardboard, tarps, paper or similar.



4. Check Existing Wall Penetrations for Levelness

It is not uncommon for windows, penetrations and openings on an exterior to be installed slightly out of level in relation to the foundation plate.

In order to determine the best plane for the Clip Starter Strip to follow, check the existing wall penetrations and transitions for levelness, using a level and tape measure up against windows, doors, soffits and openings in the stone area.

As a recommended installation best practice to achieve the most desired finish, stone should terminate level in relation to these penetrations, even if they are slightly out of level.

For example, stone should terminate level in relation to the base of a window. If the base of the window frame is $\frac{1}{4}$ " off from being level, we'll want to account for this error while setting the Clip Starter Strip. This ensures the stone will still stop even with the bottom of the window frame.

Checking window for levelness



Measuring from soffit to foundation sill plate



CLIP SYSTEM INSTALLATION

PREPARING THE WALL FOR A CLIP SYSTEM INSTALLATION

5. Install Clip Starter Strip at Base of Stud Wall

With a plan in place for Clip Starter Strip placement figured in the previous steps, the next step is to set the Clip Starter Strip. **The most critical piece before getting started is setting the Clip Starter Strip properly.** The Clip Starter Strip is a 22 gauge galvanized metal flashing that acts as a weep screed flashing and starting Clip attachment for the first row of stone.

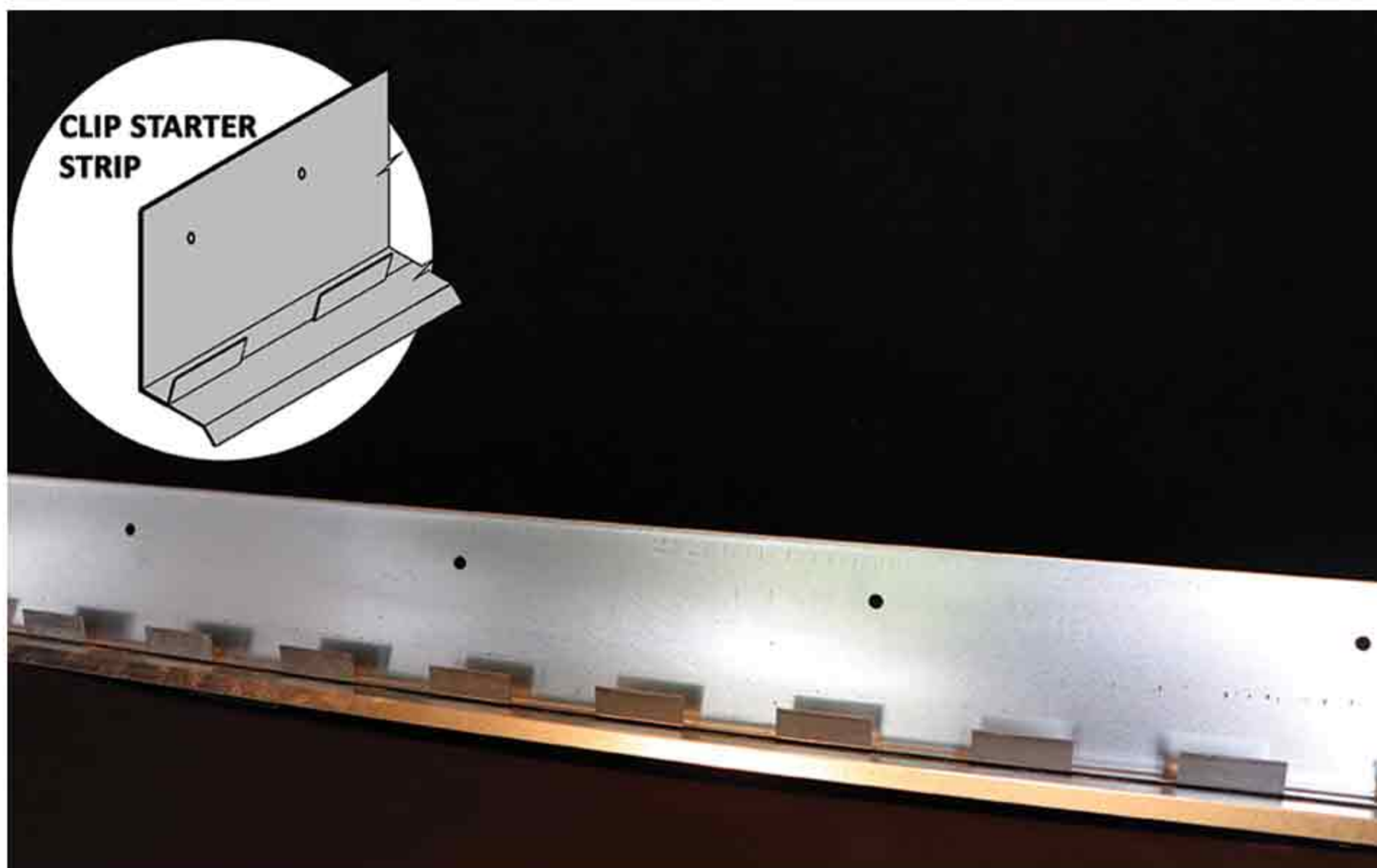

Set a Chalk Line

Using the measurements from the previous steps, measure and set a chalk line creating the line for the base of the Clip Starter Strip to follow.



Clip Starter Strip Position

Just as a traditional foundation weep screed flashing would be installed, the Clip Starter Strip is to attach directly into the wood structure, overlapping the sill plate a minimum of 1" from the stud wall down onto the concrete foundation. If an existing layer of water resistive barrier is present, the 3.5" flange of the Starter Strip should be tucked up underneath this layer. Screw the Starter Strip into the structure, bringing the WRB out over the face of the Starter Strip flange once attached. Fasteners are recommended every 8" of the Starter Strip and should be used a minimum of every 16".



The bottom of Starter Strip is to sit 4" minimum above grade (dirt), or 2" minimum above a paved surface as shown in detail QSV-32.0, page 39. This can be reduced to .5" in when paving is supported by the same foundation as the wall. Reference the NCMA for all clearances. An additional run of self-adhered rubber flashing is applied when stone continues from the framing down onto the concrete foundation, sealing the transition before the starter strip is attached overtop. Reference Detail QSV-35.0 on page 42.

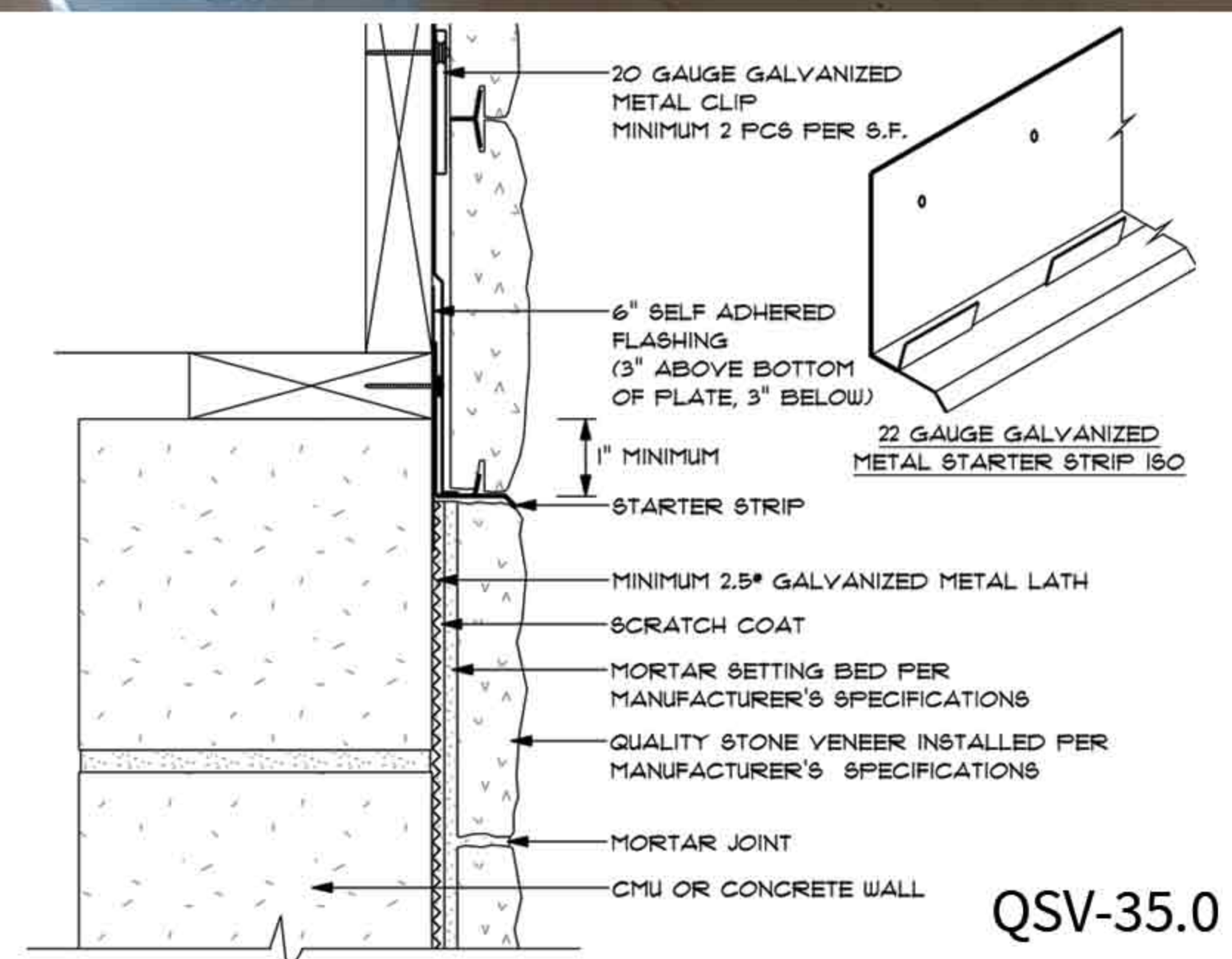

Note: Other required Starter Strip locations include horizontal floor to floor transitions at rim joist level, and above windows, doors, and framed openings described in the upcoming steps.

CLIP SYSTEM INSTALLATION

PREPARING THE WALL FOR A CLIP SYSTEM INSTALLATION

6. Secondary Layer of Water Resistant Barrier

Next, install the secondary layer of water resistant barrier. Quality Stone Veneer recommends a 60 minute grade D paper.



Using a hammer tacker, staple gun, or similar, install the water resistant barrier, beginning at the base of the wall, again overlapping the Starter Strip flange and continuing up the wall in a shingle-like fashion.



Per the NCMA, The upper layer of the WRB should lap on top of the lower layer by a minimum of 2", vertical joints should be lapped a minimum of 6", and inside and outside corners must be overlapped a minimum of 16" past the corner in both directions.

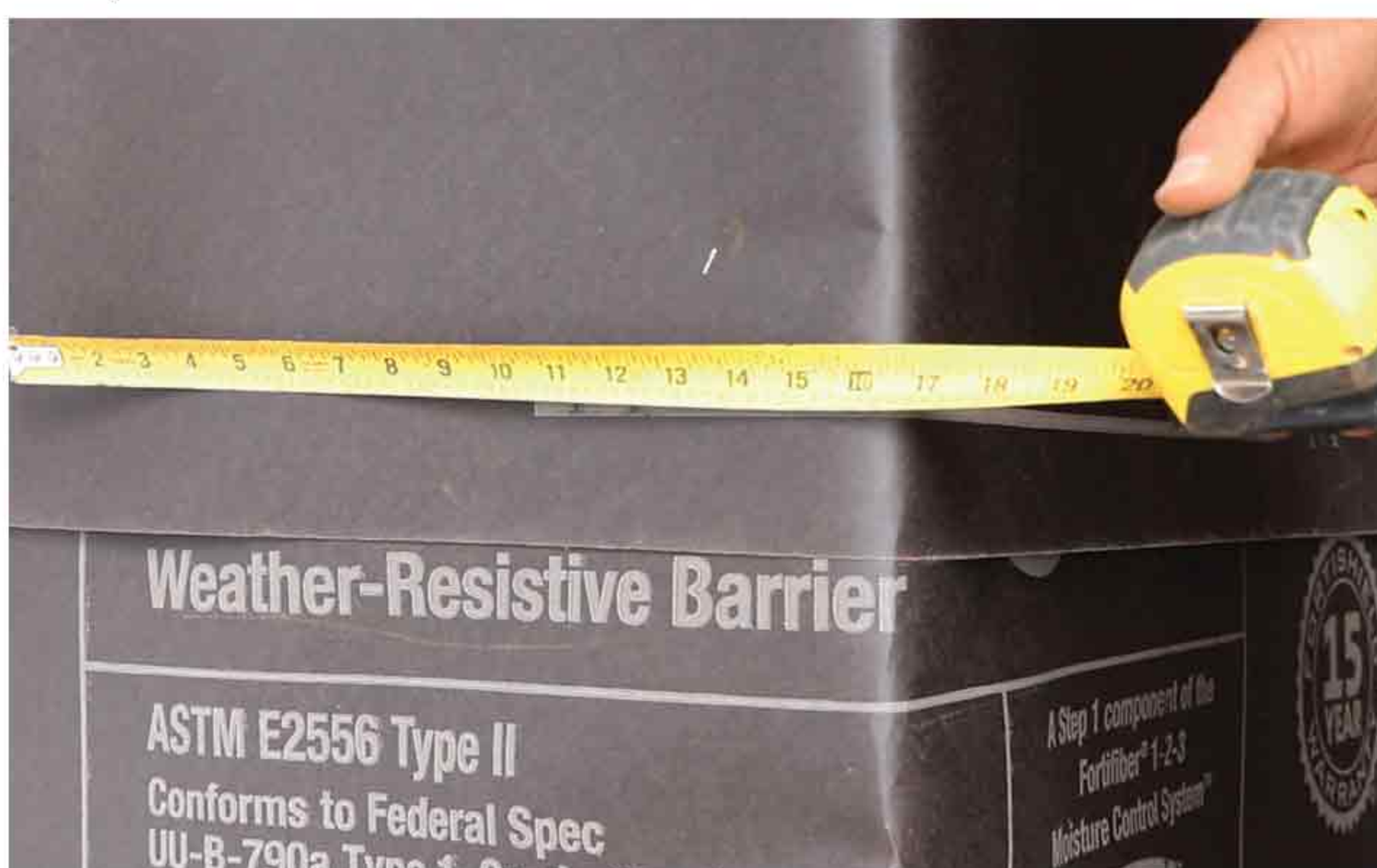

At windows and doors, the WRB should be stopped just past the top of the opening to be able to later properly integrate the remaining flashings and proceeding WRB layer overtop.



7. 6" Self-Adhered Rubber Flashing

Peel and apply 6" self-adhered rubber flashing tape at all vertical transitions to dissimilar materials, around MEP penetrations, windows, doors and additional openings in the stonework area.



Terminating the WRB just past the top of the window head has now allowed us to now apply a layer of self-adhered flashing to the top of the window before the next flashings and WRB layer are installed overtop.



CLIP SYSTEM INSTALLATION

PREPARING THE WALL FOR A CLIP SYSTEM INSTALLATION

8. Casing Bead with Factory-Applied Backer Rod

With the self-adhered flashing in place, install vinyl casing bead with factory-applied backer rod at all 4 sides of windows, at doors, framed openings, and vertical transitions to dissimilar materials in the stone area. This installation practice allows for a required 3/8" flexible joint between products that can be caulked later, and provides a precise termination point to perfectly cover any cut ends of stone.

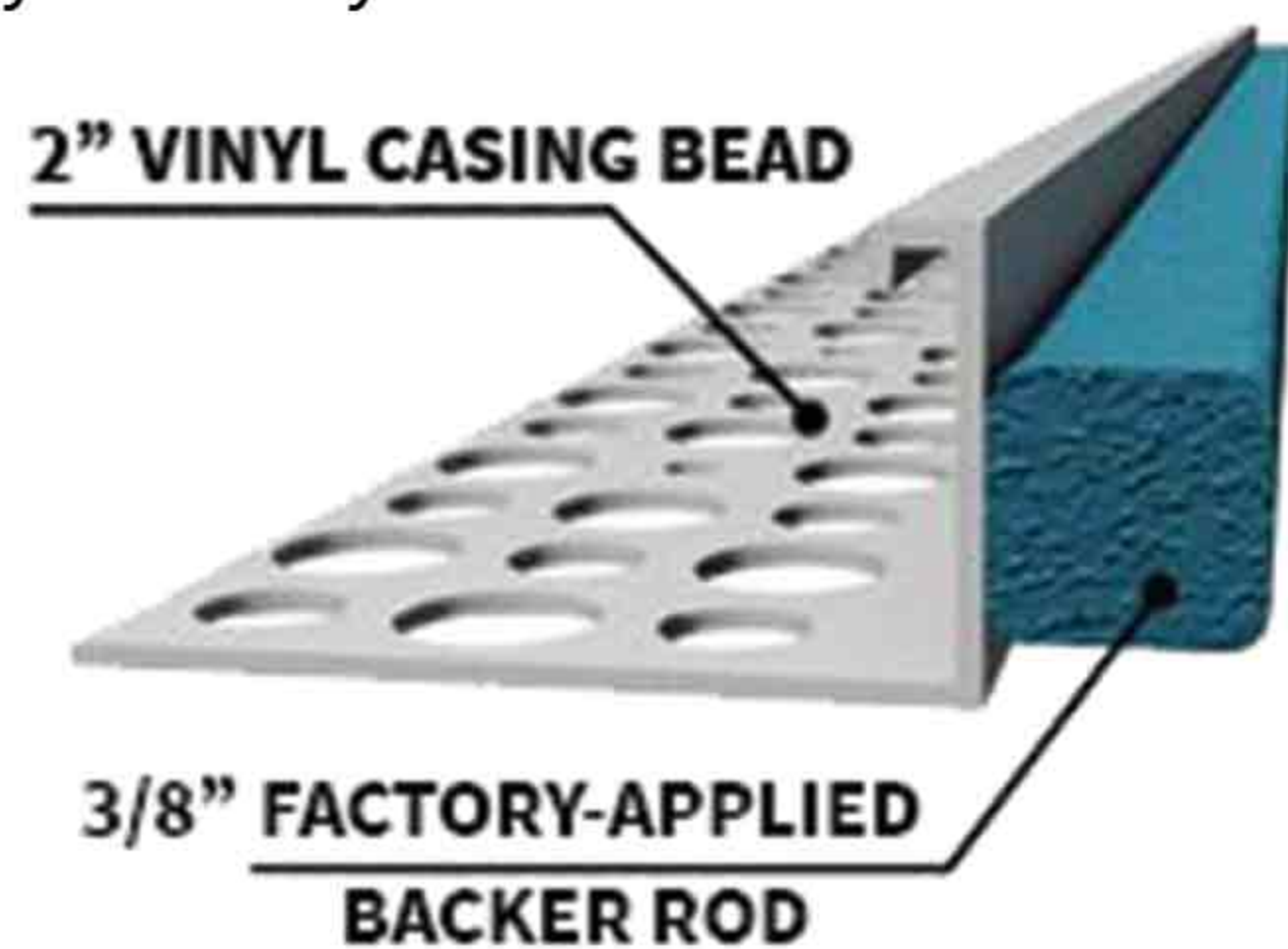

Multiple sizes of casing beads are available with a 2" being the standard for vertical transitions. A 1.5" casing bead is commonly used horizontally above and below windows so that the flange is not exposed.

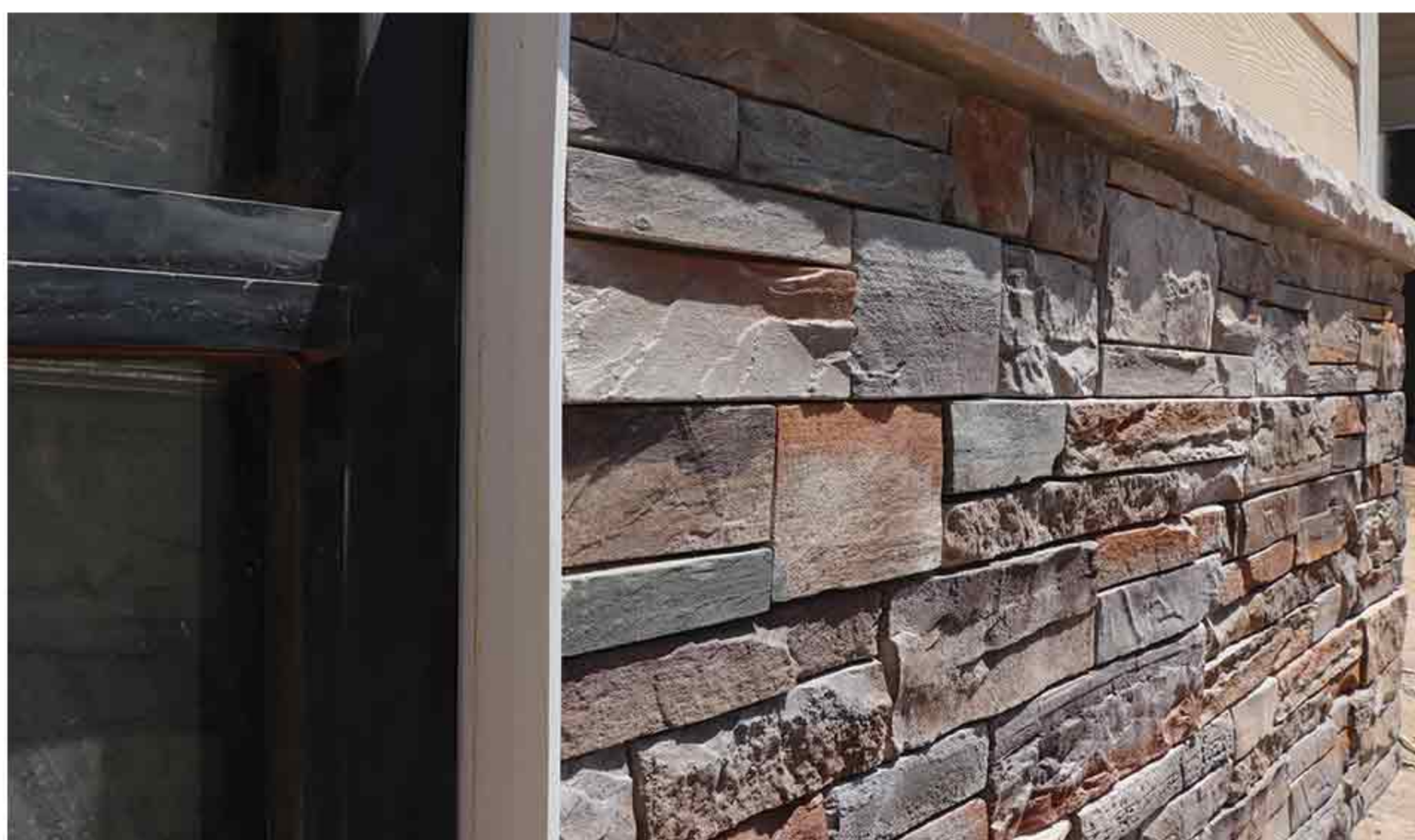

Note: For all required clearances and stone gapping to dissimilar materials, reference page 14 of this guide.

9. Clip Starter Strip Above Windows, Doors and Framed Openings

Set and attach the Starter Strip above windows, doors and framed openings. Place the Starter Strip immediately on top of the casing bead, being sure not to compress the spacing the foam backer rod provides. Screw the piece into the structure using the corrosion resistant Clip Screw.



The Starter Strip is to extend the length of the window plus 1" of overhang in each direction.



The Starter Strip Flange is then overlapped by the proceeding WRB layer.



Note: Refer to window and door details on pages 14, 36, 37, 40 and 43 for more information.

CLIP SYSTEM INSTALLATION

PREPARING THE WALL FOR A CLIP SYSTEM INSTALLATION

10. Expansion Joint Locations

Using an approved corrosion resistant fastener, install galvanized expansion joints to provide for movement, and to accommodate expansion and contraction caused by initial wall shrinkage and minor thermal movement.

Install galvanized expansion joints at changes in wall heights, adjacent to changes in materials and at windows and doors where possible, as a continuation of the break the vertical casing bead creates at the side of the opening. Spacing not to exceed 15 foot on center in any direction.



Vertical Expansions

The standard galvanized expansion joint should be used for all vertical expansions (*Pictured above*).

Horizontal Expansions

The Clip Starter Strip is used for all horizontal expansion locations.



Note: See Clip System Detail QSV-34.0: Floor to Floor Transitions on page 41.



DO NOT CAULK HORIZONTAL EXPANSIONS

Starter Strip at horizontal expansions should not be caulked. The base of the Starter Strip is required to be left open in all areas for moisture to drain.

11. Staging Stone Material on Jobsite

Stone boxes should be staged so that product from multiple boxes can be used throughout the entirety of the installation. This is a necessary step to create a diverse and even blend of coloring across the entire wall.



CLIP SYSTEM INSTALLATION

PRODUCT INSTALLATION

1. Extending the Groove For First Row

All Clip System styles have a groove to accept the corrosion resistant Clips on all sides. For strength in shipment, this Clip System groove does not extend to the outside edge of the product.

On the first course of stone only, use a masonry saw to extend the groove throughout the bottom of each piece. This allows the first course of stone to sit flush and evenly down onto the starting Clip attachment the Starter Strip provides.



2. Setting the First Corner

Product installation must begin at the outside corner first, working horizontally row by row across the wall. Beginning at the outside corner, place the first corner piece down onto the Starter Strip interlocking the Clip attachment into the groove.



The corner piece should sit flush with the Starter Strip following the plane planned for when measuring and setting the Starter Strip. Check to be sure the piece is sitting all the way down onto the tabs of the Starter Strip.

Pictured: Eggshell Historic Brick

With the corner in place, add a Clip to each side of the corner and fasten into the wall with the corrosion resistant Clip Screw.



3. Set the Return Flat

In the case of a short return, as shown here, set and attach the first flat before the second corner is installed overtop. Attach two Clips to the flat minimum.



Pieces can be cut to the desired length when required using a mitre saw with a vacuum attachment and HEPA Filter. Cut pieces face down to minimize dust.



WARNING

- Stone should only be cut outdoors in a well ventilated area.
- Proper eye, hearing and respiratory protection should be worn.

CLIP SYSTEM INSTALLATION

PRODUCT INSTALLATION

4. Set the Second Corner

The majority of Lambris styles will require the second corner to be installed before setting the first large flat, since the large flat will interlock with this height.

Using a polymer-modified mortar, place a thin bead of mortar overtop the first installed corner on both legs of the corner. Mortar should be placed in front of the Clips. This mortar acts as a setting bed for the next piece and adds an additional firmness to the product once cured.



Set the second corner over the first. The second corner will be flipped offsetting the first corner. Again, attach to the wall using two Clips, one to each leg of the corner.



5. Set the Horizontal and Vertical String Lines

Using the Starter Strip as the reference point, measure and set a horizontal string line to act as the horizontal control. Set a vertical string line at the outside corner to act as the vertical control.

String lines are important to keep rows in plane horizontally and corner sections true vertically as the install continues up and across the wall.



6. First Large Flat

Following the same procedure from before, place a bead of mortar over the stepped offsets of the corner piece where the first flat will interlock.

Set the first large flat into place locking into the existing corners. This creates the start to the first row.



Fasten the flat to the wall once it's sitting flush with the Starter Strip. Use two Clips to the top of the piece and one on the offset leg. Continue installing across the wall using the designated pattern for the Lambris style being installed. Follow the same procedure, placing the mortar bead in front of the clips, setting the next flat overtop and attaching with the Clips.



CLIP SYSTEM INSTALLATION

PRODUCT INSTALLATION

7. Adjust the Horizontal String Line Upwards

With the first row of product installed, install the next corner pieces and adjust the horizontal string line upwards accordingly. Continue to use the horizontal string line as the horizontal control, and the vertical string line against the outside corner.

Again, using the installation procedures discussed in the previous steps, continue installing across and up the wall until reaching the opposing termination points.

The brick will be grouted in the finishing steps.



8. Installing Clip System Precast Accessories

Quality Stone Veneer Lambris precast accessories can be attached with Clips, or direct applied using mortar and wire lath.



Note: Precast accessories are most commonly direct applied in areas subject to fixture attachment or contact, such as light blocks, outlet blocks, or sills at low kneewalls and windows.

Direct Applying Precast Accessories

Where direct applying precast accessories, drain mat is required to be used in conjunction with the mortar and wire lath to replicate the drainage plane the Clip System installation provides. Drain mat ensures the continuous drainage plane is maintained behind the system, and further eliminates the possibility of moisture damming up behind the product. For direct application of a precast sill, drain mat is cut to the size of the sill area and installed first.

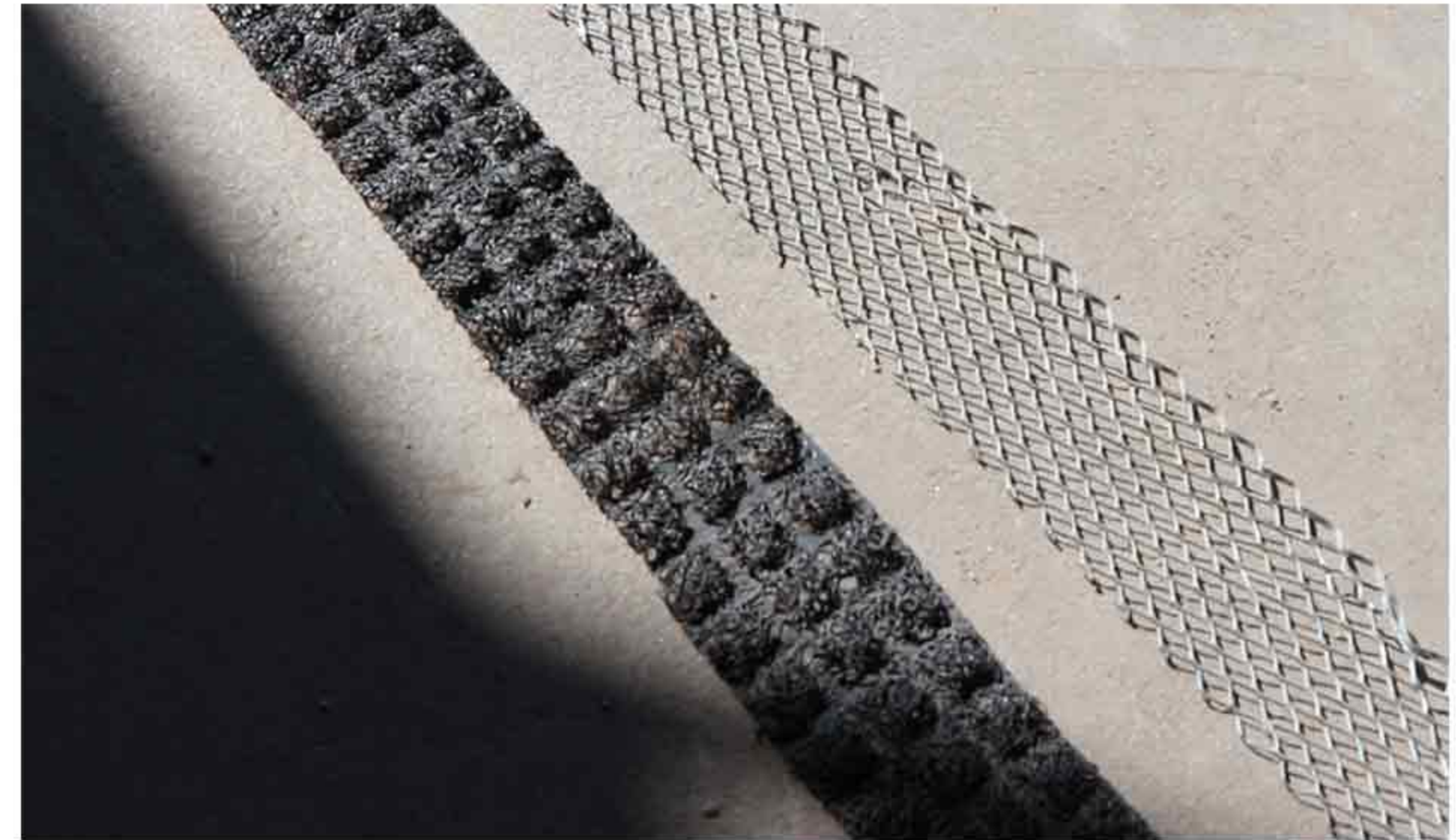

Next, wire lath is cut to the same dimension and installed over the drain mat. Using a polymer modified mortar, a scratch coat is applied, and then the sill is set overtop. The drain mat provides an airspace between the wall and mortar.



CLIP SYSTEM INSTALLATION

PRODUCT INSTALLATION

9. Continuing the Wall Section

The Clip System makes it easy to transition the wall section into a different product, all while maintaining the same continuous drainage plane between the wall.

In this example, the *Historic Brick* kneewall will transition into Quality Stone Veneer's *Apilada*.

Following the installation procedures from before, a thin bead of mortar is set over the section of the sill to receive the corner, and the first corner is attached.



With the first corner attached, the second corner will install next as the largest flat size will again interlock with this two-corner height.

Adjust the horizontal string line upwards and begin installing stone flats to the left until reaching the termination point.



The same procedures should be followed throughout, placing a thin bead of mortar to the existing pieces in front of the Clips, setting the flat, and attaching to the wall using two Clip to the top of the flat and one Clip to the offset leg. Use the horizontal control to verify each flat is sitting within plane of the rest.

Setting the Return Flat Before Next Row of Stone



When approaching a termination point, such as the window shown here, the vinyl casing bead with factory-applied backer rod will allow for the spacing required between the stone and the termination. This piece also caps and covers the cut ends of the stone for a clean finished look. Be sure not to compress the spacing the foam backer provides at these transitions.



Note: When adding the thin mortar bead between the panels, be sure to place the mortar across both the horizontal and vertical sections. Mortar is always added in front of the Clips. Example areas above highlighted in yellow.

CLIP SYSTEM INSTALLATION

PRODUCT INSTALLATION

10. Preparation for Terminating Stone at the Top of the Wall Section

As the top of the wall section is approached, the final row of product can be directly applied in the space where Clips can otherwise be difficult to fit. This is most common when stone meets the soffit on the underside of a roof overhang.

Drain mat, lath, mortar scratch coat and finally the stone product are installed in this space finishing out the wall section. It is recommended to install the drain mat, wire lath and mortar scratch coat before the second to last course of stone is installed.



11. Precast Header Installation

A wide variety of precast Lambris Lintels and Accents are available, which include the Clip System Groove in the back of the piece allowing for a Clip System installation.

At the top of the window, slide the piece down onto the Starter Strip, locking it into place. Place Clips on top of the piece, spaced 12" on center, and fasten to the wall.



Clip System Installation of a Lintel



Finish out by installing the final flats in the remaining areas. The smallest flat size in each Lambris style are beneficial in small spaces to minimize cutting. Direct apply the remaining flats in the space previously prepared with drain mat, lath and mortar scratch coat.



Note: Refer to pages 34-35 to review product Grouting, Finishing and Clean Up.



DIRECT APPLICATION

PREPARING THE WALL FOR A MORTAR AND WIRE LATH INSTALLATION

1. Jobsite Safety Inspection

Before beginning any work on site, verify workspace is safe and free from all hazards. Use a jobsite safety inspection checklist like the one shown on page 5 of this guide. All workers should be equipped with the proper personal protective equipment for the job.

“We Choose Safety First.”

2. Pre-Installation Steps

Refer to the details beginning on page 15 of the Clip System Installation section of this guide. Follow all requirements and procedures for best pre-installation practices including:

- Ensuring all necessary terminations, flashings, penetrations, and trim pieces are in place.
- Protecting existing finished materials, including finished flatwork below the workspace and plastic covering around windows, doors, trim, siding and additional protrusions in the stone area.
- Checking existing wall penetrations for levelness. Use a level and tape measure up against windows, doors, soffits and openings to first create a plan for the stone to follow.



Determining a Plan for the Stone Installation



3. Install Drip Cap at Base of Stud Wall

In this example, the product will be installed over a standard OSB, plywood substrate just as pictured with the Clip System installation previously. A key difference from a Clip System installation, in a direct application over OSB drip cap is used at the base of the stud wall as the foundation weep screed flashing, instead of the Clip Starter Strip.



Pull the existing layer of paper up to attach drip cap directly into the wood structure with approved fastener. In the field, the sill plate should be overlapped a minimum of 1" from the stud wall down onto the concrete foundation, as detailed in the NCMA Installation Guide.

Drip Cap at Foundation in a Direct Application



DIRECT APPLICATION

PREPARING THE WALL FOR A MORTAR AND WIRE LATH INSTALLATION

4. Secondary Layer of Water Resistive Barrier

Install the secondary layer of water resistive barrier, again overlapping the flange of the drip cap at the base of the stud wall. **Note: When stone is to continue below the drip cap onto the foundation, a run of self-adhered rubber flashing is required to be applied over the plywood to concrete foundation transition before the drip cap is attached overtop.**

5. Wall Opening Weeps

Wall Opening Weeps are used in combination with drain mat to create a better foundation drainage for the system, and mimic the drainage plane a Clip System Installation would provide. WOW's create an airspace between the mortar for moisture to drain freely out and away from the structure.



Install the Wall Opening Weeps overtop the secondary layer of water resistive barrier, sitting flush with the drip cap. Wall Opening Weeps should be set every 24" on center.



6. 6" Self-Adhered Rubber Flashing & Casing Bead with Factory-Applied Backer Rod

Self-adhered rubber flashing and casing bead should be integrated with the secondary layer of WRB around all openings and transitions in the stonework area, as shown in the Clip System section of this guide beginning on page 18.

7. Drip Cap and Wall Opening Weeps at Window Head

These products are also to be used above all windows, doors and framed openings in the stone area.

At the window head, attach drip cap immediately overtop the casing bead being sure not to compress the spacing the foam backer rod provides. Drip cap should extend 1" past the window in both directions.



The flange of the drip cap is to then be overlapped by the preceding layer of water resistive barrier.



Wall Opening Weeps installed evenly at window head, overtop secondary layer of WRB



DIRECT APPLICATION

PREPARING THE WALL FOR A MORTAR AND WIRE LATH INSTALLATION

8. Expansion Joint Locations

Just as with a Clip System Installation, expansion joints should be installed to provide for movement, and to accommodate expansion and contraction caused by initial wall shrinkage and minor thermal movement. Install galvanized expansion joints at changes in wall heights, adjacent to changes in materials and at windows and doors where possible, as a continuation of the break the vertical casing bead creates at the side of the opening. Spacing not to exceed 15 foot on center in any direction.



Vertical Expansions

The standard galvanized expansion joint should be used for all vertical expansions. Gap stone to each expansion joint by $3/8$ " (Pictured Above). This can be caulked by others.

Horizontal Expansions

As detailed for foundation drainage at the base of the stud wall, Drip Cap and Wall Opening Weeps are used in the same manner for all horizontal expansions, most usually being a floor to floor transition.*

Expansion at Windows, Doors, Transitions and Framed Openings

The casing bead with factory-applied backer provides space for movement in these areas. *Caulking Pictured*

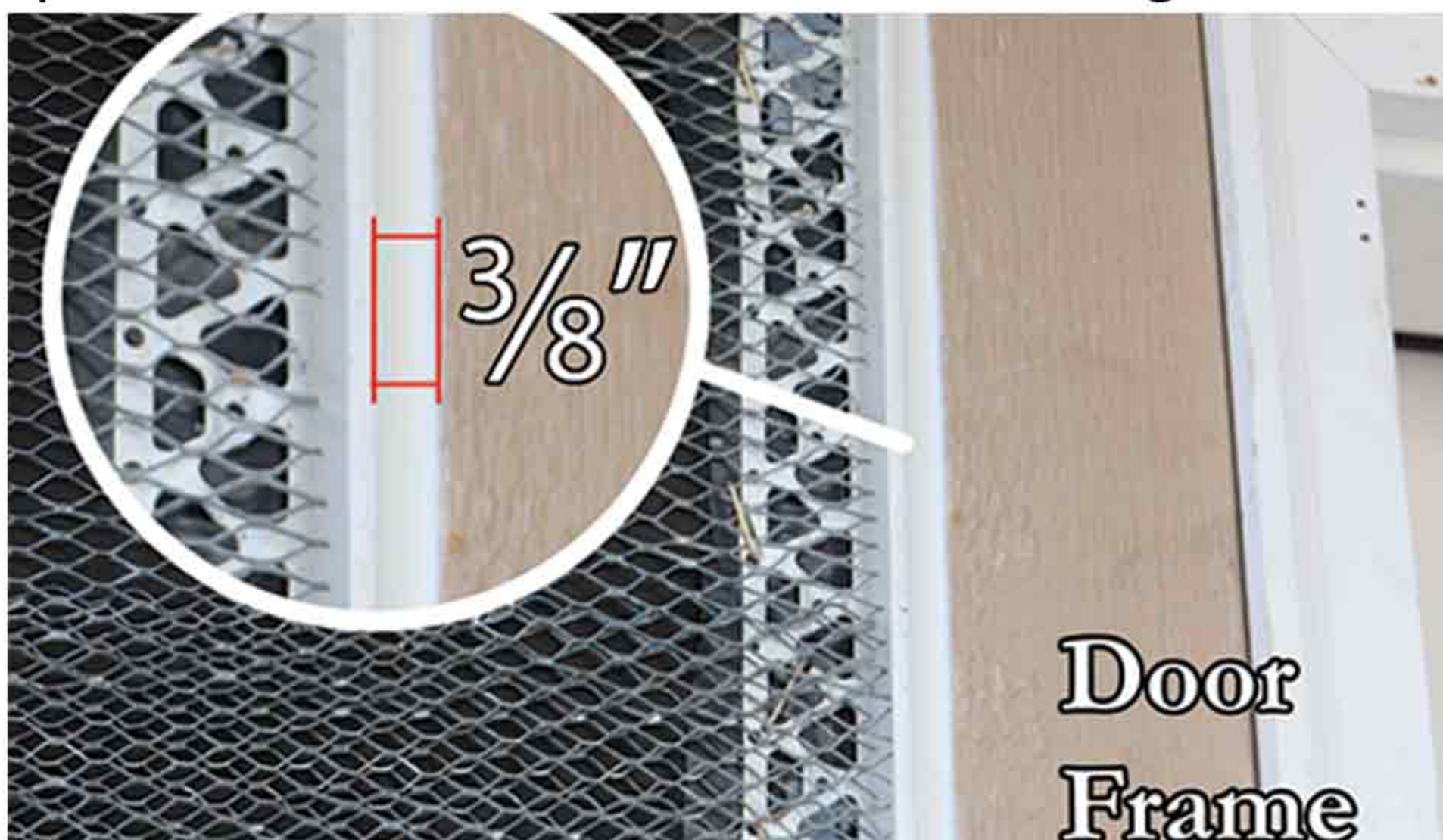

9. Drain Mat Installation

Install drain mat, often also referred to as *rain screen*, over the wall system. Begin installing first at the base of the wall, overlapping the foundation drip cap and wall opening weeps. Drain mat provides the $1/4$ " airspace between the wall and mortar scratchcoat for moisture to drain freely.

Drain mat should be installed felt side out, with the plastic ridges facing down into the wall. Overlap the drain mat layers with the designated felt boarder around the outside of the product.



Drain Mat at Window Head



10. Install Wire Lath

Install wire lath using the correct corrosion resistant fastener for the designated wall type. Dimples of the lath should be facing towards the wall. Reference the NCMA for current fastener and lath requirements based on the wall type. Lath should overlap a minimum of 1" at vertical seams, .5" at horizontal seams, and must wrap around inside and outside corners a minimum of 12".

*  **DO NOT CAULK HORIZONTAL EXPANSIONS**

Drip Cap and WOW 's at horizontal expansions should not be caulked. This transition is required to be left open in all areas for drainage.

DIRECT APPLICATION

PREPARING THE WALL FOR A MORTAR AND WIRE LATH INSTALLATION

Lath Installation



Fastening Lath at a Window Flange

When fastening lath beside a window, be careful not to use fasteners within 2" of the window to avoid penetrating the flange around the window. Failure to hold fasteners away from the flange can often void a window manufacturer's warranty.



11. Mortar Scratch Coat

With the lath in place, the next step is to mix and apply the mortar scratch coat. For all direct applications of Lambris styles, Quality Stone Veneer specifies a polymer modified mortar for scratch coat and stone application to improve bond strength and curing. Polymer modified mortar should be compliant with ANSI A118.4 or ANSI A118.15.



Applying the Scratch Coat



12. Leveling the Scratch Coat: Darby Tool

A Darby is a leveling tool Quality Stone Veneer specifies to level all scratch coat areas. This is an important step to fill in any voids or raised areas that may be slightly different in depth or height, such as at lath overlap or wall variance. With the darby, begin at the base of the wall and firmly work the tool upwards, leveling the mortar as it is shuffled upwards.



Rake the scratch coat once it is leveled.



13. Scratch Coat Curing Requirements

The scratch coat is required to dry a total of 24 hours or longer until fully cured before the stone installation can begin. In winter months, up to 50% type S premix can be blended with the polymer modified mortar to improve curing in cold temperatures.

DIRECT APPLICATION

PRODUCT INSTALLATION

1. Getting Started with a Direct Application

Stone boxes should be staged so that product from multiple boxes can be used throughout the entirety of the installation. This is a necessary step to create a diverse and even blend of coloring across the entire wall.

With the mortar scratch coat fully cured for 24 hours minimum, the product installation can begin. Mix and prepare the polymer modified mortar for product application.

2. Setting the First Corner

Mud the back of the first corner using a generous amount of mortar, being sure to push the mortar fully into the corner.



Beginning at an outside corner, adhere the first corner to the wall, pushing it into the wall fully until it sits flush in plane with the drip cap.

Rake and sweep off any excess mortar that is extruded out from the back of the corner. This is a very important step so that the next piece can be placed evenly on top.



3. Setting the First Flat

Set the first large flat next, interlocking with the installed corner. Adhere the piece, again sweeping off any excess mortar that seeps out from behind.



In the event of a void behind the flat once it is level and in plane, additional mortar can be shoveled in to fill the space.



4. Set the Next Corner

Set the next corner offsetting the first with the longer leg.



DIRECT APPLICATION

PRODUCT INSTALLATION

5. Set the Horizontal and Vertical String Lines

With the first two corners installed, next measure and set a horizontal string line to act as the horizontal control. The string line should be set in relation to the drip cap. Set a vertical string line at the outside corner to act as the vertical control.

These string lines are important to keep rows in plane horizontally and corner sections true vertically as the install continues up the wall.



6. Continue the Pattern

Continue to the first row using the designated pattern for the Lambris style you're installing, until reaching the opposing termination point.



Note: Pieces can be cut when required using a mitre saw with a vacuum attachment and HEPA Filter.

Pieces should be cut face down to minimize dust on the face of the product. Keep excess on hand to tooth in at the end of a wall section where required.



WARNING

- Stone should only be cut outdoors in a well ventilated area.
- Proper eye, hearing and respiratory protection should be worn.

Finishing Out the First Course



7. Second Course

Once ready to begin the second course, install the next corner piece and reset the horizontal stringline.



DIRECT APPLICATION

PRODUCT INSTALLATION

8. Direct Applying Precast Accessories

With the brick kneewall completed, a precast sill can be installed overtop, before transitioning into the next style. (*Metropolitan Brick Sill Pictured*)

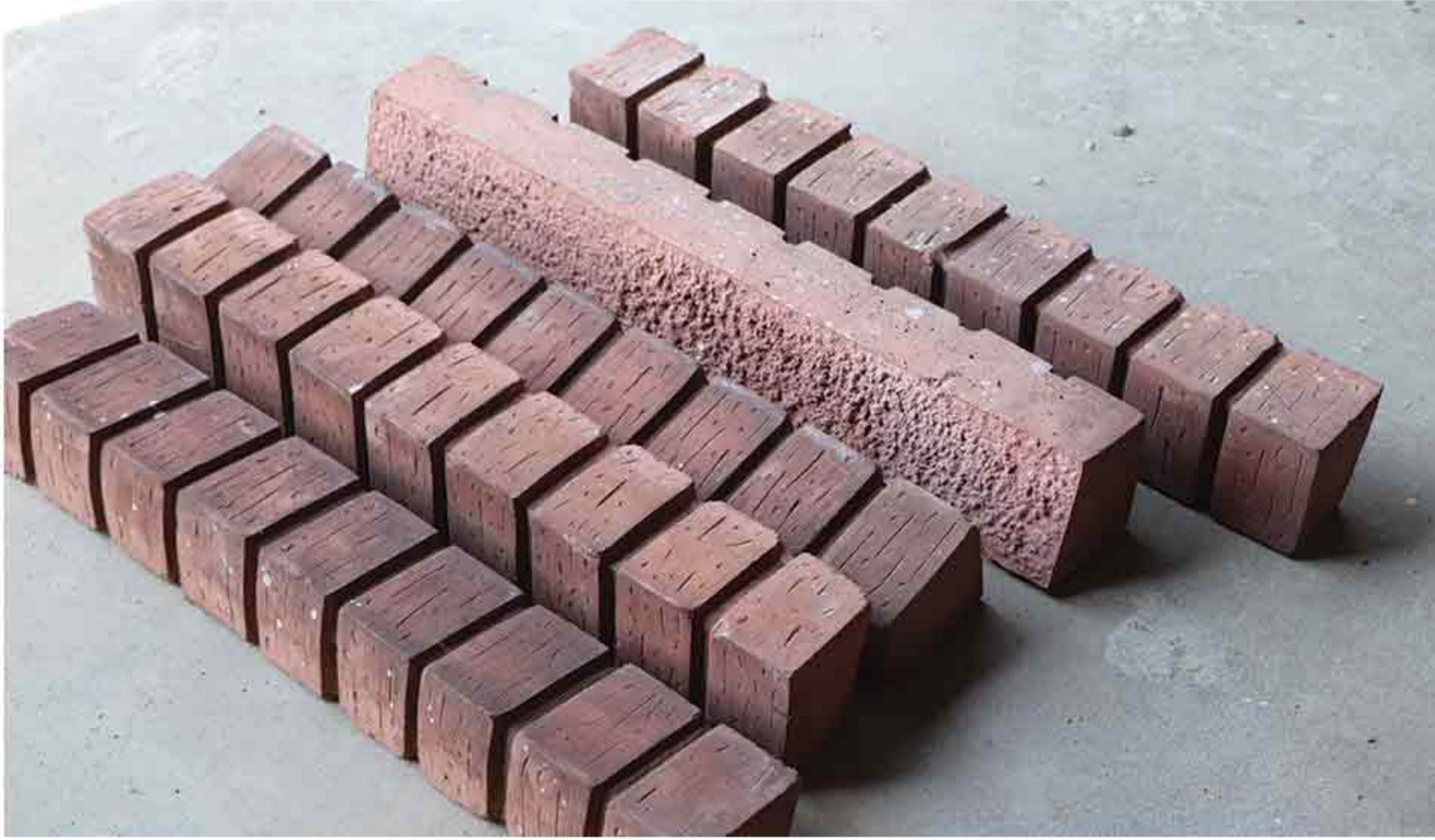

Sills can be cut at a 45 degree angle at outside corners to join two sills together.



Completion of the Kneewall



9. Continuing the Wall Section

In this example, the *Metropolitan Brick* kneewall will transition into Quality Stone Veneer's *Urbana Fusion*. See pages 34-35 for grouting and finishing procedures for Lambris thin brick and jointed stone styles.

Set the first corners following the same direct application procedures from before. Measure for the horizontal stringline and adjust it upwards for the first row of stone.



Installing the First Row of Stone



DIRECT APPLICATION

PRODUCT INSTALLATION

10. Adjust the Horizontal String Line Upwards

In completion of the first row of stone, reset the string line again, continuing the install pattern up and across the wall.

For each flat that is set, remember to rake and sweep excess mortar from the top of the piece. Push mortar behind the piece filling any voids between the wall and the stone.



11. Precast Header Installation

Upon reaching the window head, in this example installed is a *Siota Lintel*. Mortar the back of the piece and press into the wall. Check with a level and screw into the wall using the wire tabs in the back, firmly securing the lintel into the structure.



Leveling the Lintel



Attaching the Lintel



DIRECT APPLICATION

PRODUCT INSTALLATION

12. Finishing the Remainder of the Stone

Continue installing stone following the steps outlined in this guide. Cut pieces when required to fill the remaining wall space.

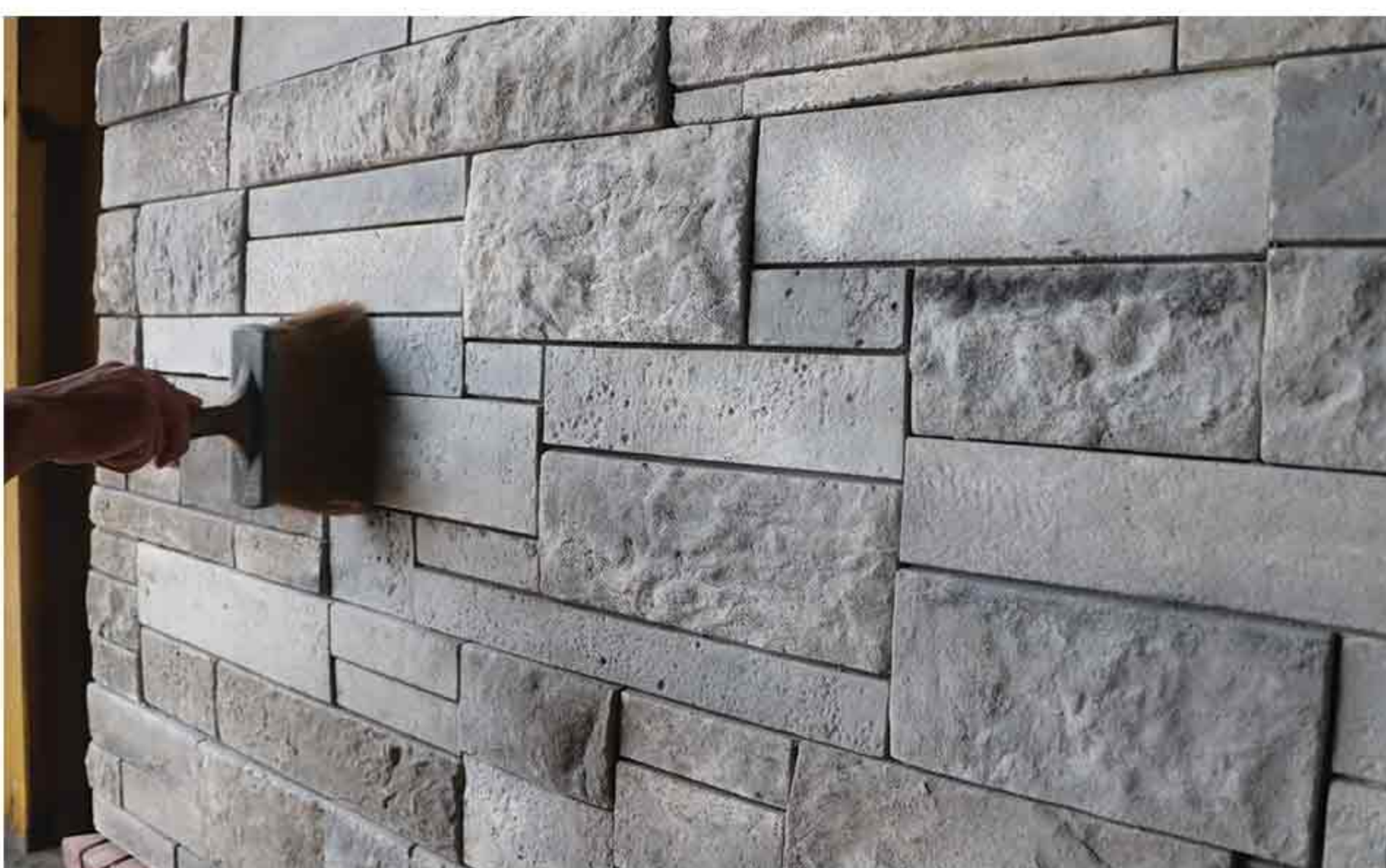

13. Score and Break Excess off Wall Opening Weeps

Score the bottom of each wall opening weep with a utility knife, breaking off the excess flush with the stone. Brush any mortar out of the WOW that may have fallen into it during installation.

Removing Excess WOW at Window Head



Removing Excess WOW at Foundation



Note: Refer to pages 34-35 to review product Grouting, Finishing and Clean Up.

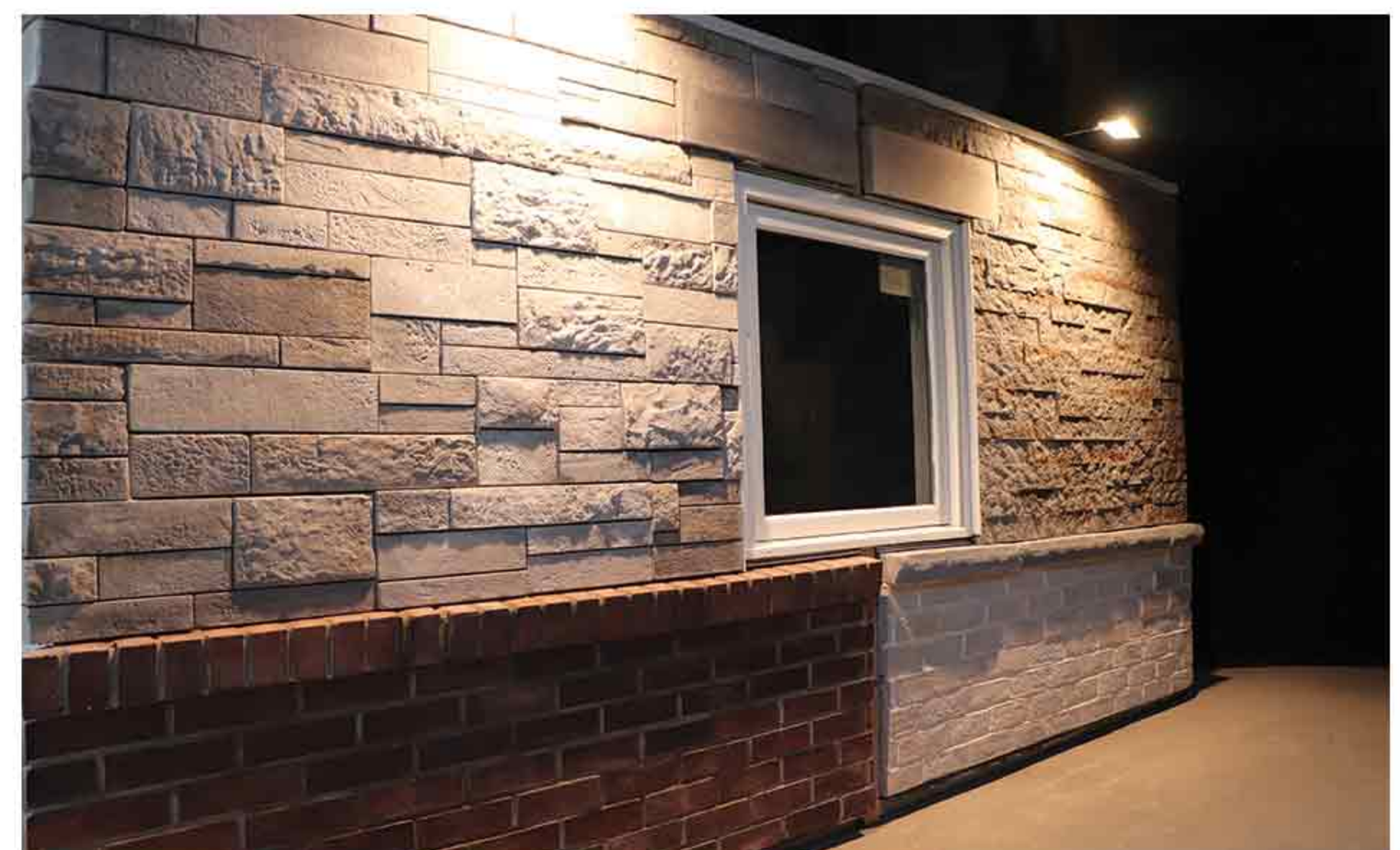

STONE FINISHING PROCEDURES

FINAL PRODUCT GROUTING AND FINISHING

Grouting the Product

It is recommended to wait 1 week after the product is installed before beginning grouting to allow for building settlement.

Brick Grouting

(Historic Brick & Metropolitan Brick Styles)

Spray and soak the first section of brick to be grouted with water to improve the mortar bond. Focus on a wall section small enough that can be completed before any mortar curing takes place.



Using a polymer modified mortar, begin grouting the horizontals first, followed by the verticals.

1. Grouting the Horizontals



2. Grouting the Verticals



Rake the Joints

Using a masonry slicker, rake the joints immediately beginning with the vertical joints first, and the horizontal joints second.



Brush and Sweep the Brick Face

Using a masonry brush, clean the excess mortar off the face of the brick.



Brush Face Cleaning

In areas where mortar has spilled over the face of the stone or brick, a soft bristle masonry brush can be used to lightly clean and remove the excess mortar.*



WIRE BRUSHING

Hard bristle wire brushes can damage the face of the product.

STONE FINISHING PROCEDURES

FINAL PRODUCT GROUTING AND FINISHING

Grouting Clip System Stone Styles

On Lambris styles that require a mortar joint after install, such as Cobblestone Lambris and Fieldstone Lambris, follow these same principals.

Although, as with traditional mortared stone installations, allow the joints to become thumb print hard before raking.



Raking the Joints



Field Dyeing and Stone Finishing

A Quality Stone Veneer Finishing Kit should be used on touch up areas as a final face treatment, as well as on any exposed cut ends of stone.

1 pint of stain is recommended per 500 square feet of installed product, or 1 quart per 1,000 square feet. A matching stain is paired specific to the base colorway of the product.

Stain may be sprayed or brush applied. When sprayed, hold the applicator 6" back from the face of the stone. A towel can be used to blend into the face when required, and to wipe and remove any running dye.

Finishing Kit



Dyeing the Stone

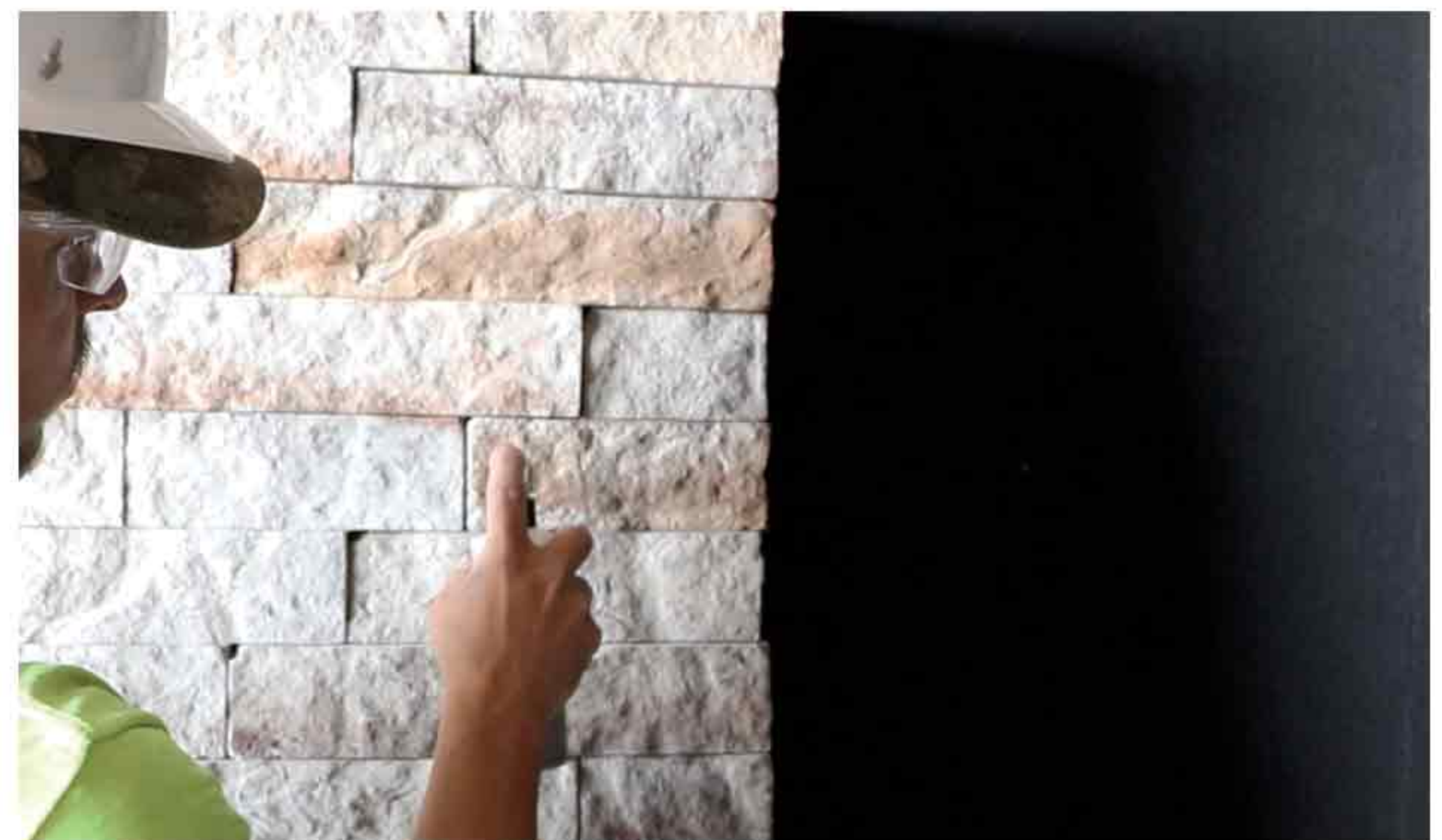

Final Face Cleaning

A high power blower, such as a leaf blower, can be used as a final face cleaning to the stone. This is helpful in removing any excess dust that may have settled onto the pieces during cutting and installation.



Note: A high pressure washer may damage the face of the stone. Quality Stone Veneer does not recommend this method of cleaning. Low pressure water spray, or a medium bristle (nonmetal) brush is more suitable for cleaning stone veneer products. Acid washing can damage the stone face textures and is not recommended. Improper cleaning and finishing procedures could lead to damage and in-turn, a loss of warranty coverage.

CLIP SYSTEM INSTALLATION DETAILS

WINDOW PREPARATION AND UNDERLAYMENT FOR A CLIP SYSTEM INSTALL

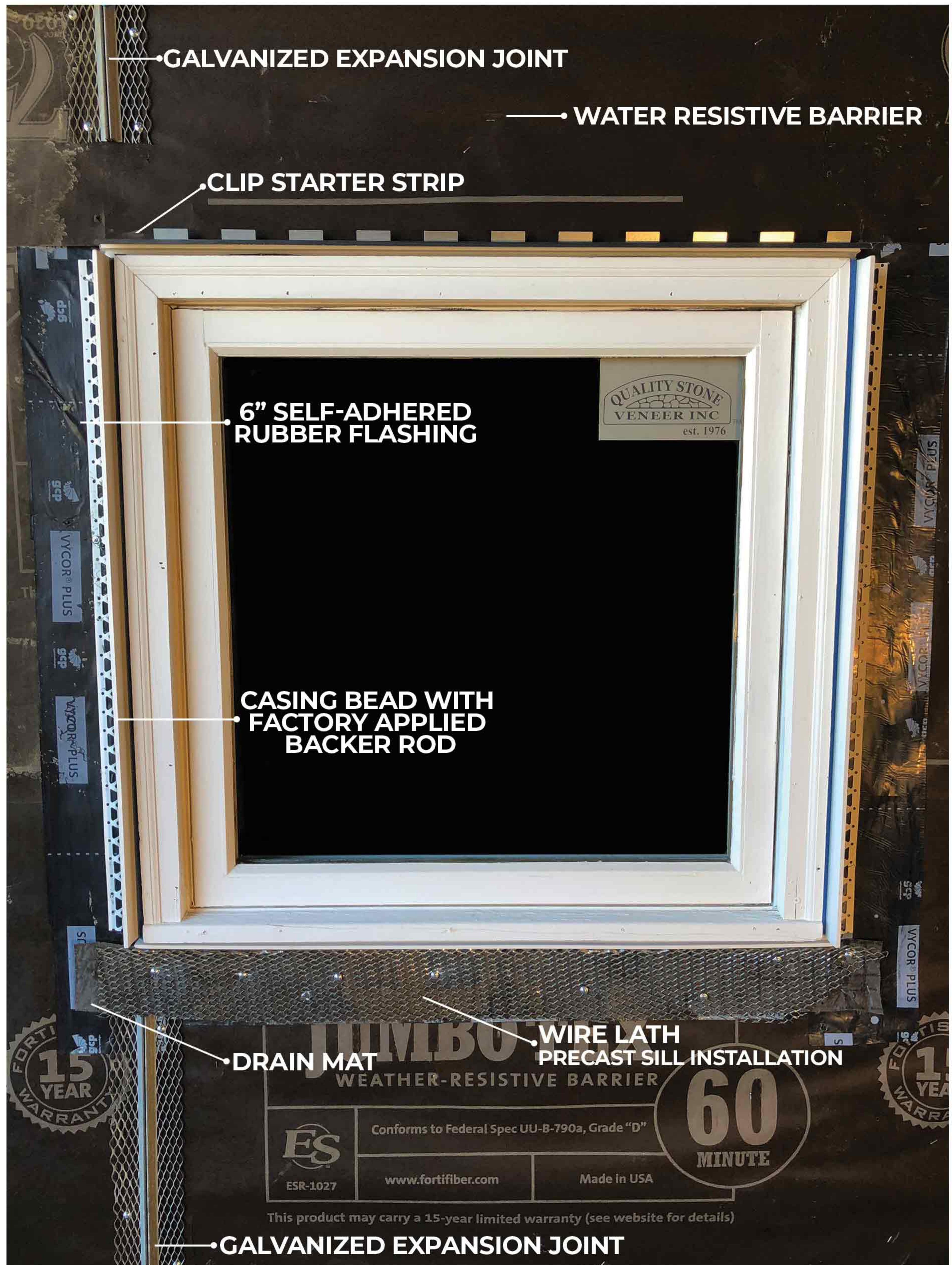

CLIP SYSTEM INSTALLATION DETAILS

WINDOW PREPERATION AND UNDERLAYMENT PROCEDURE

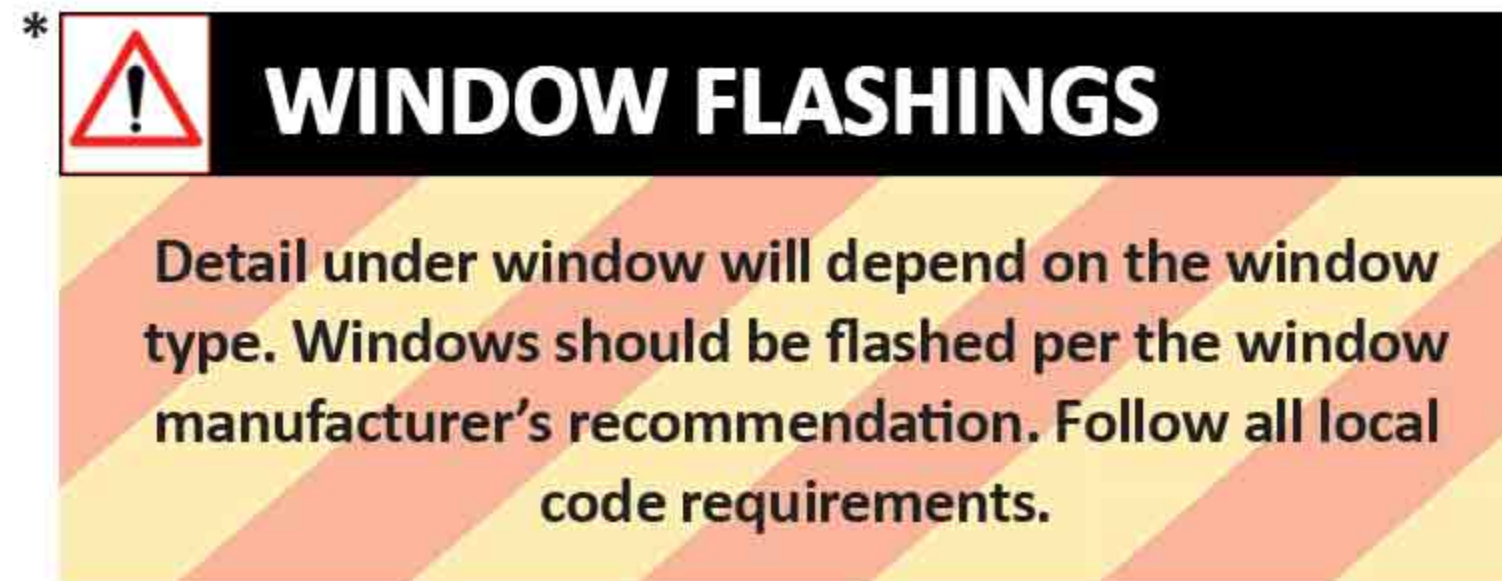
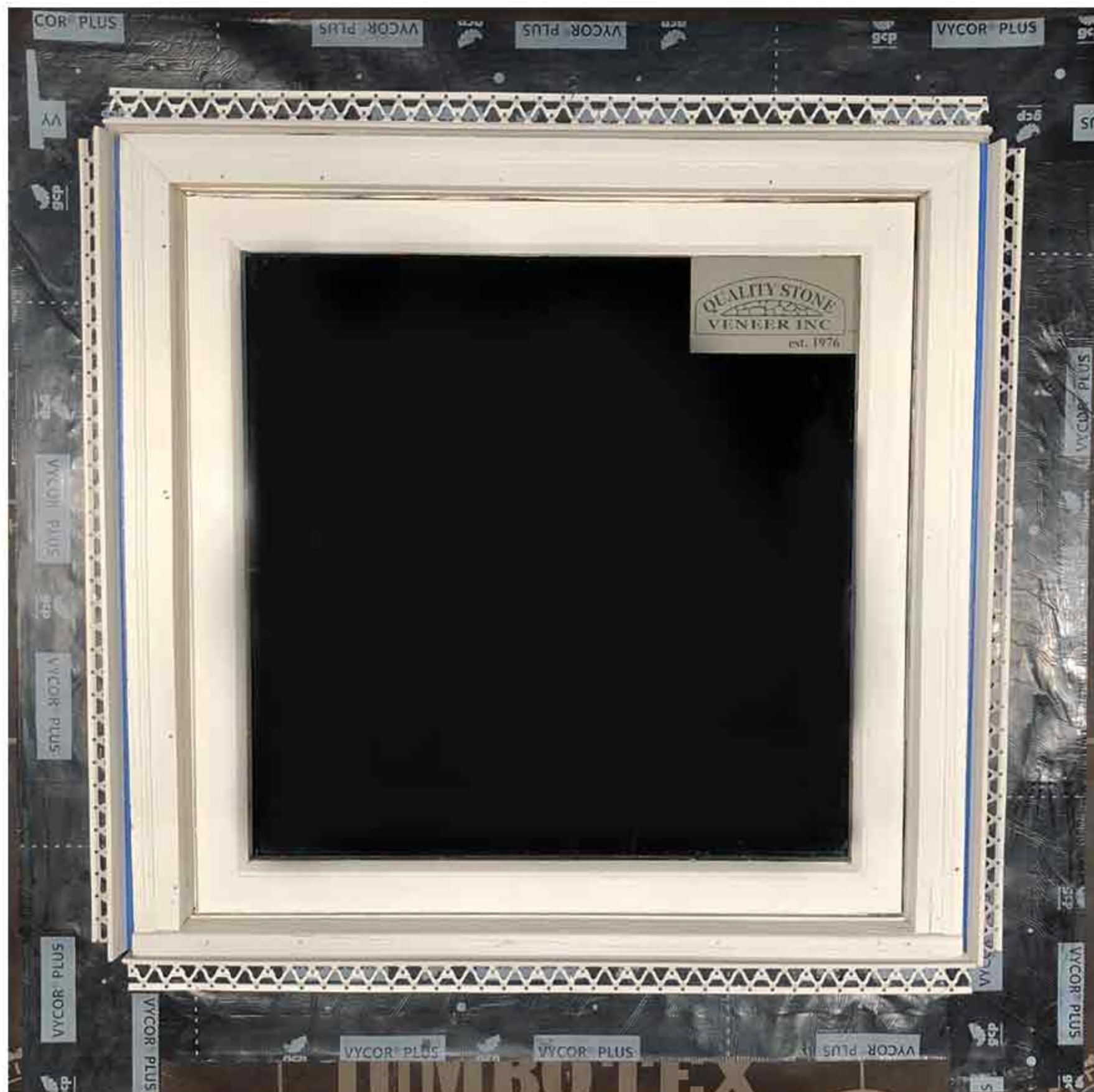

1



- WATER RESISTIVE BARRIER
- 6" SELF-ADHERED RUBBER FLASHING
- CASING BEAD WITH FACTORY APPLIED BACKER ROD

*See note on right for window flashing.

2



- CLIP STARTER STRIP AT WINDOW HEAD INSTALLED OVERTOP VYCOR & CASING BEAD
- STARTER STRIP IS TO EXTEND THE LENGTH OF THE WINDOW + 1 INCH OF OVERHANG IN BOTH DIRECTIONS



3



- CLIP STARTER STRIP AT WINDOW HEAD WITH NEXT WRB LAYER OVER FLANGE

4

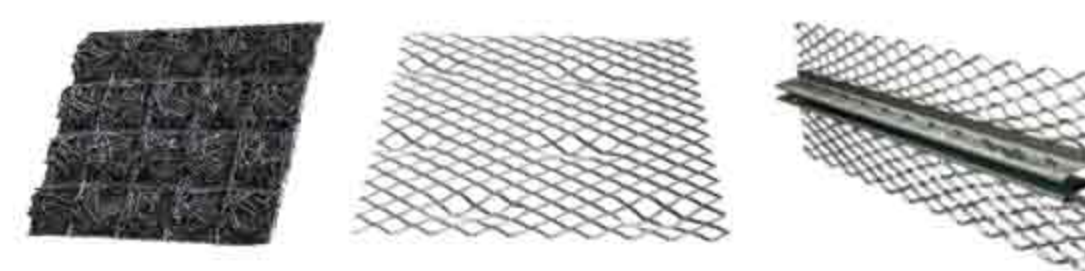

- DRAIN MAT BEHIND LATH: REQUIRED FOR DRAINAGE
- WIRE LATH FOR PRECAST SILL MORTARED INSTALLATION
- GALVANIZED EXPANSION JOINTS

CLIP SYSTEM INSTALLATION DETAILS

CLIP SYSTEM AT KNEEWALL

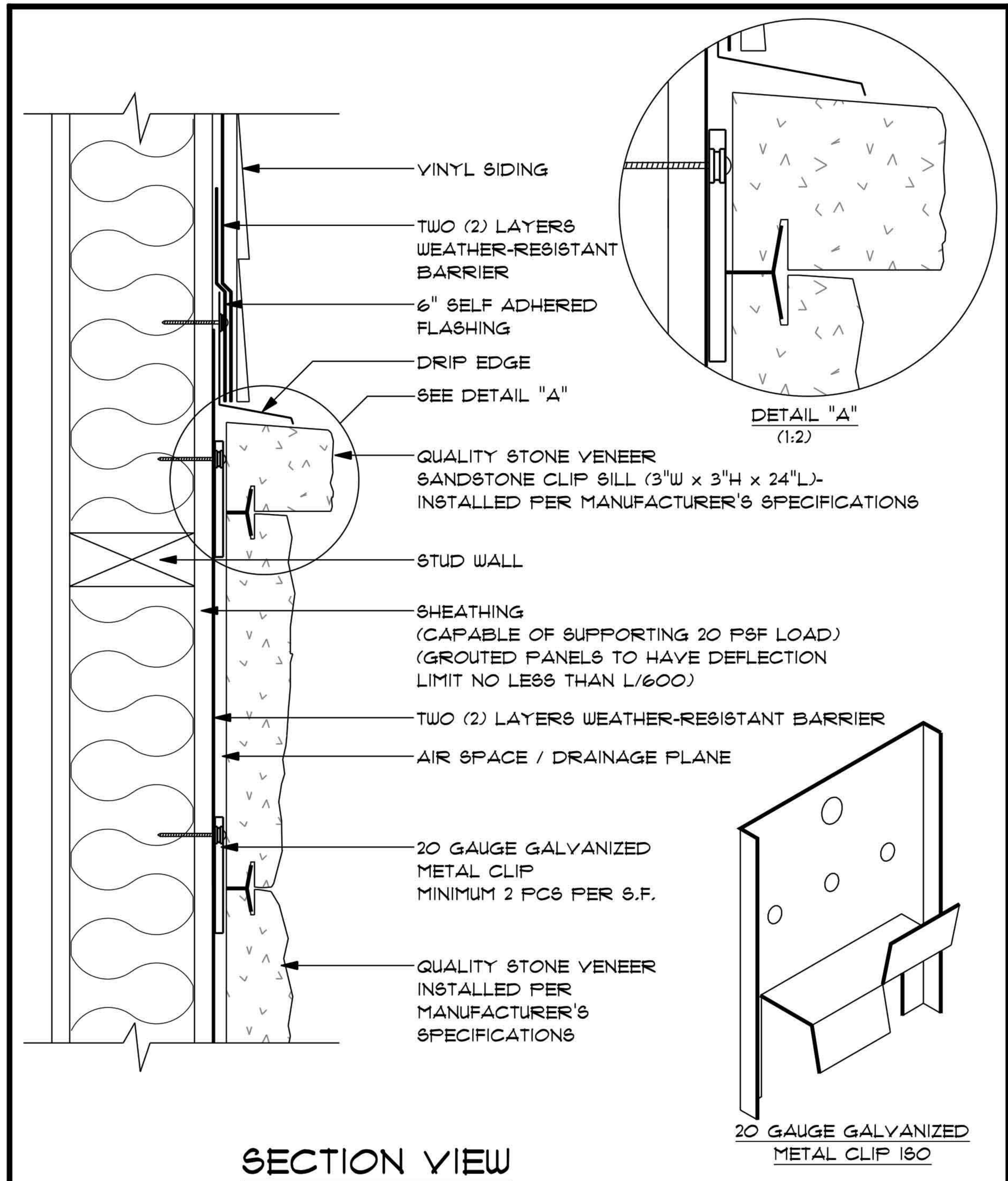

QSY-31.0

SCALE: 3" = 1'-0"

MANUFACTURED STONE
CLIP SYSTEM AT KNEE WALL

FOR STUCCO, MASONITE,
WOOD & VINYL SIDING

Rev. 8/18/2020

QUALITY STONE VENEER

PHONE: 1-800-795-3229
FAX: 717-786-4038

WWW.QUALITYSTONEVENEER.COM

QUALITY STONE VENEER INC

est. 1976

CLIP SYSTEM INSTALLATION DETAILS

CLIP STARTER STRIP AT FOUNDATION

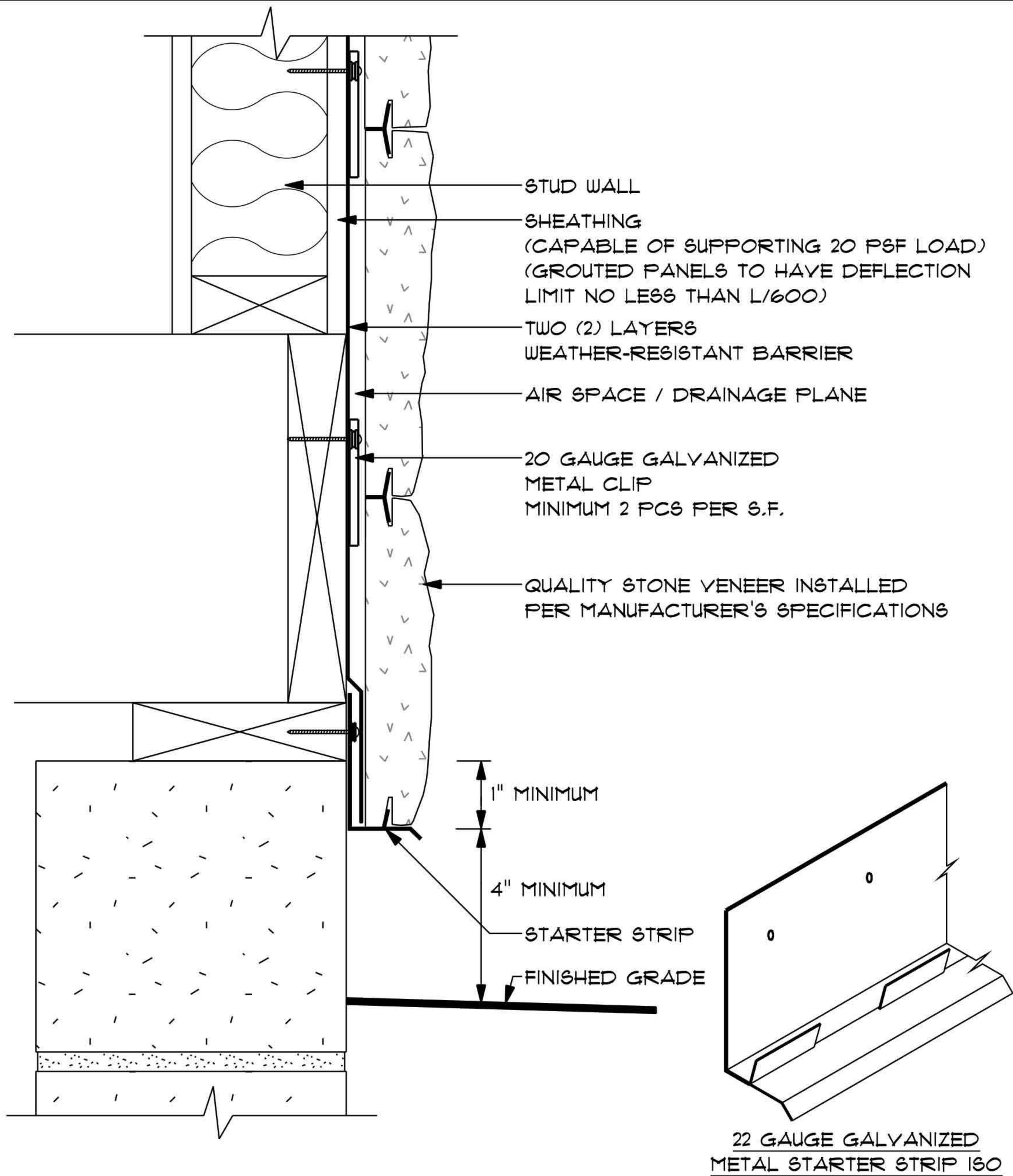

SECTION VIEW

Rev. 8/18/2020

QSV-32.0

SCALE: 3" = 1'-0"

MANUFACTURED STONE
CLIP SYSTEM ON STUD WALL

STARTER STRIP INSTALLED AT C.M.U.

QUALITY STONE VENEER

PHONE: 1-800-795-3229
FAX: 717-786-4038

WWW.QUALITYSTONEVENEER.COM



est. 1976

CLIP SYSTEM INSTALLATION DETAILS

CLIP SYSTEM AT TOP OF WINDOW

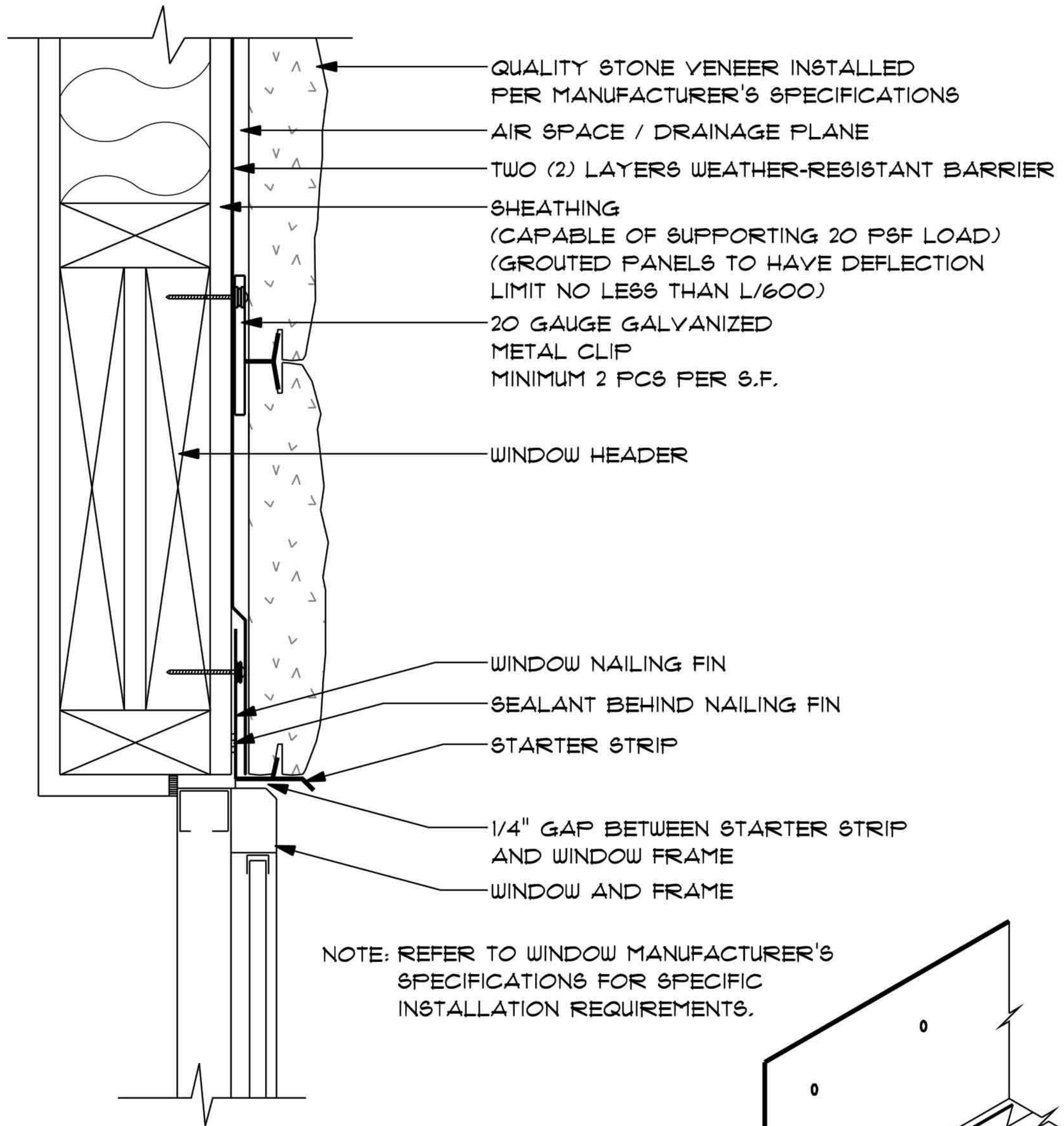

SECTION VIEW

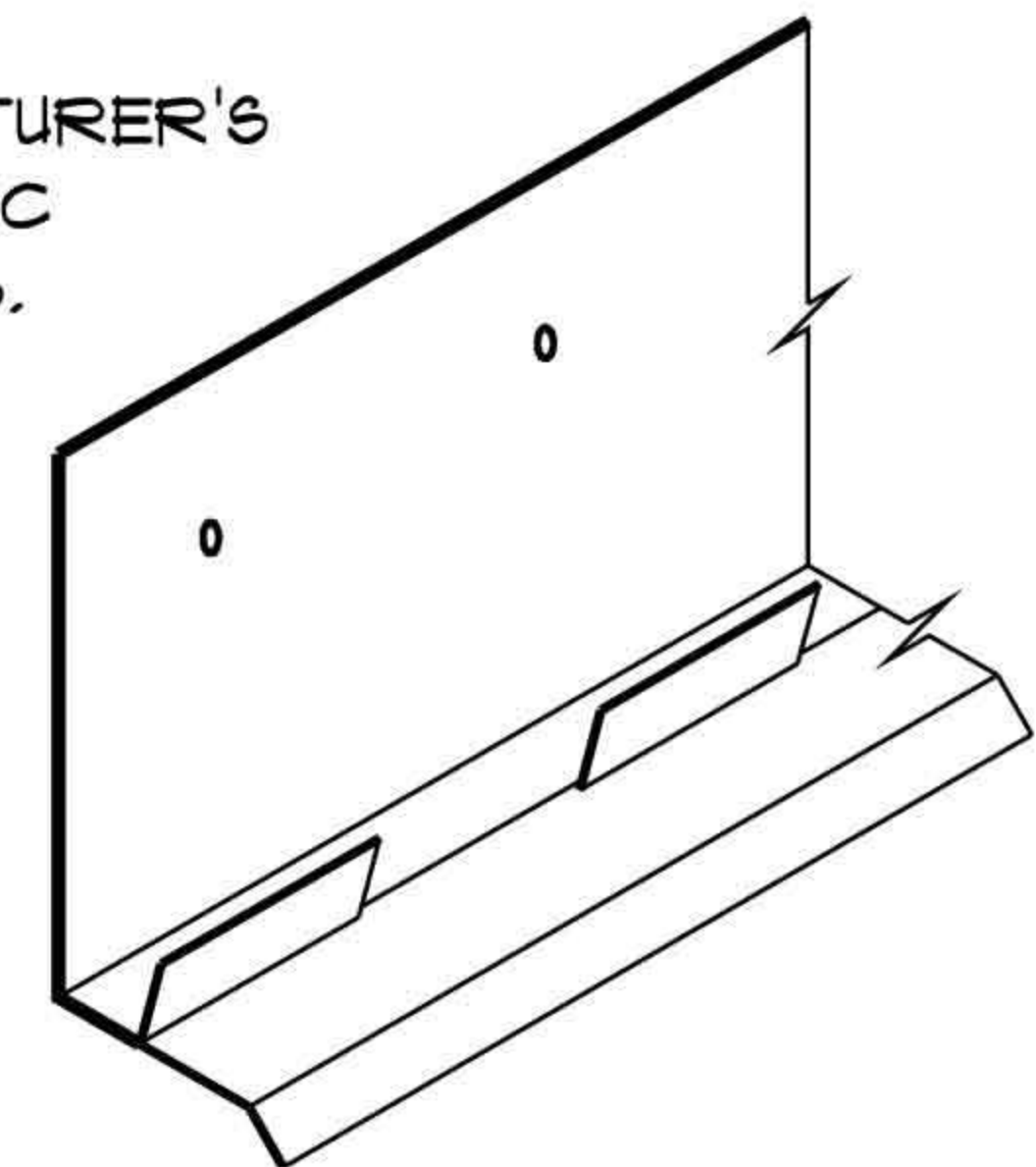

22 GAUGE GALVANIZED METAL STARTER STRIP ISO

Rev. 8/18/2020

QSY-33.0

SCALE: 3" = 1'-0"

TOP OF WINDOW DETAIL AT MANUFACTURED STONE w/ CLIP SYSTEM

INSTALLATION AT STUD WALL

QUALITY STONE VENEER

PHONE: 1-800-795-3229
FAX: 717-786-4038

WWW.QUALITYSTONEVENEER.COM



est. 1976

CLIP SYSTEM INSTALLATION DETAILS

FLOOR TO FLOOR TRANSITION

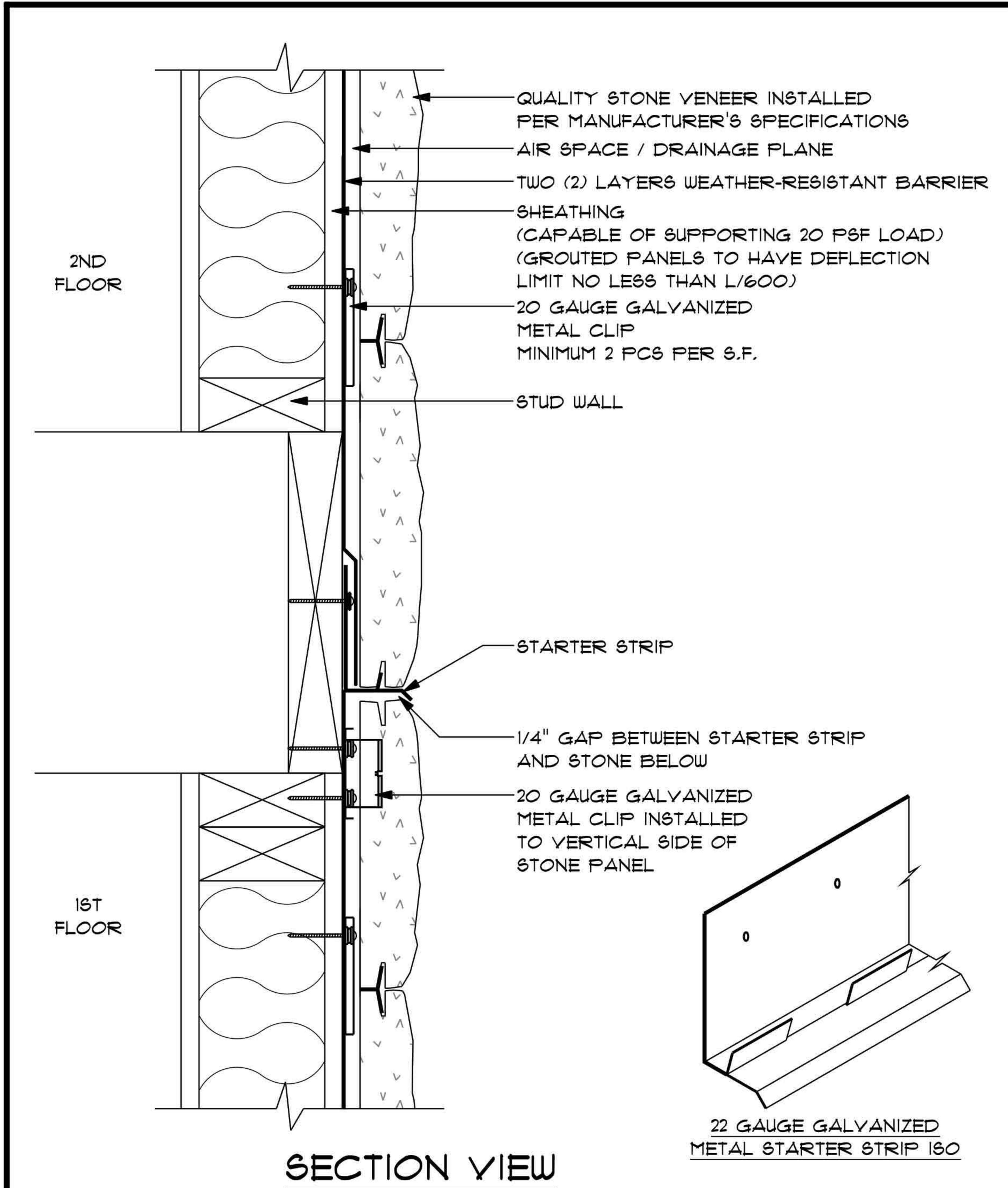

QSV-34.0

SCALE: 3" = 1'-0"

TRANSITION BETWEEN EACH FLOOR MANUFACTURED STONE w/ CLIP SYSTEM

INSTALLATION AT STUD WALL

Rev. 8/18/2020

QUALITY STONE VENEER

PHONE: 1-800-795-3229
FAX: 717-786-4038

WWW.QUALITYSTONEVENEER.COM

QUALITY STONE VENEER INC

est. 1976

CLIP SYSTEM INSTALLATION DETAILS

STUD WALL TO FOUNDATION WALL TRANSITION

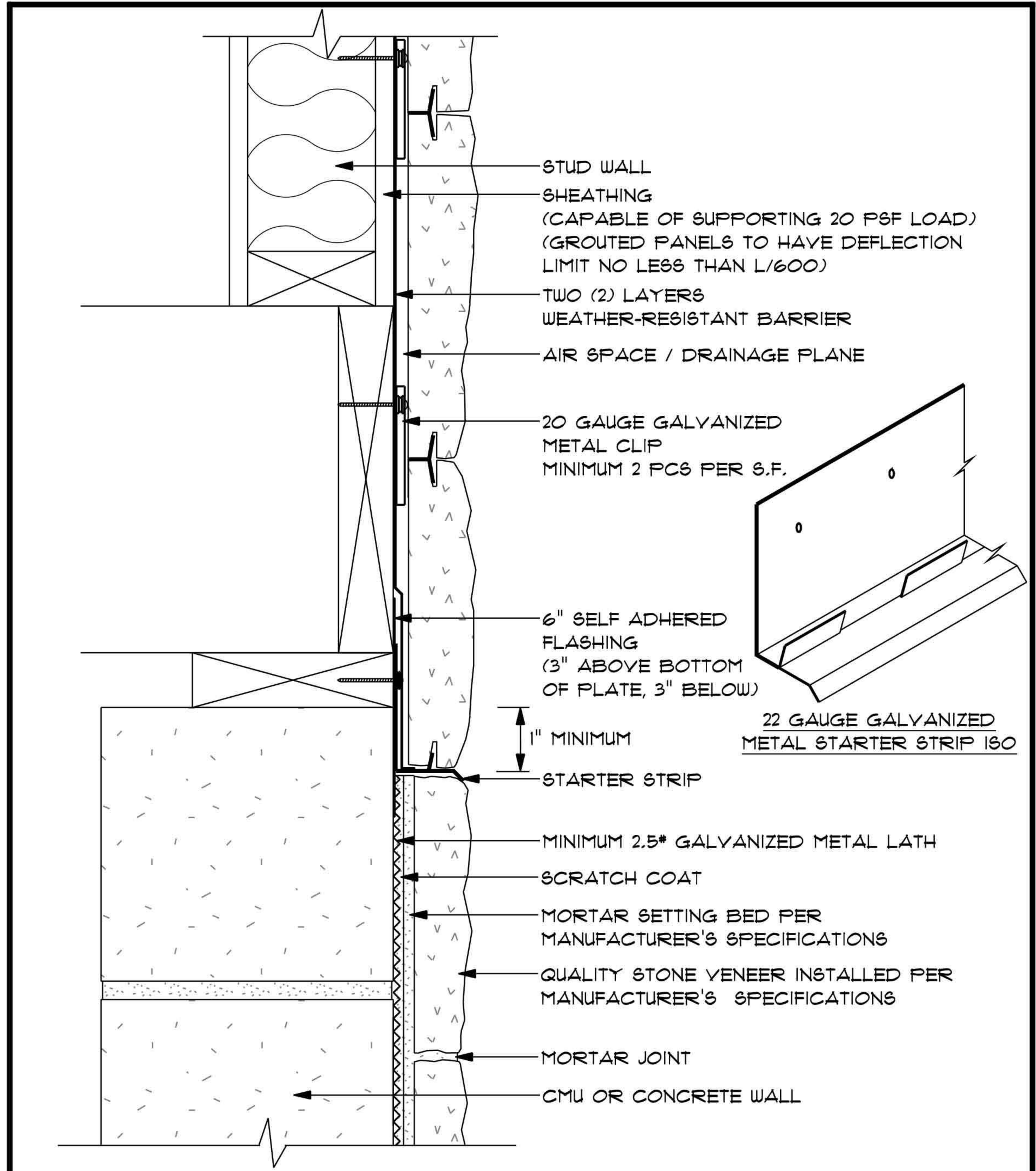

SECTION VIEW

Rev. 8/18/2020

QSV-35.0

SCALE: 3" = 1'-0"

MANUFACTURED STONE
CLIP SYSTEM ON STUD WALL
AND MANUFACTURED STONE
AT FOUNDATION WALL

STARTER STRIP INSTALLED AT C.M.U.

QUALITY STONE VENEER

PHONE: 1-800-795-3229
FAX: 717-786-4038

WWW.QUALITYSTONEVENEER.COM



est. 1976

CLIP SYSTEM INSTALLATION DETAILS

CLIP SYSTEM AT SIDE OF WINDOW

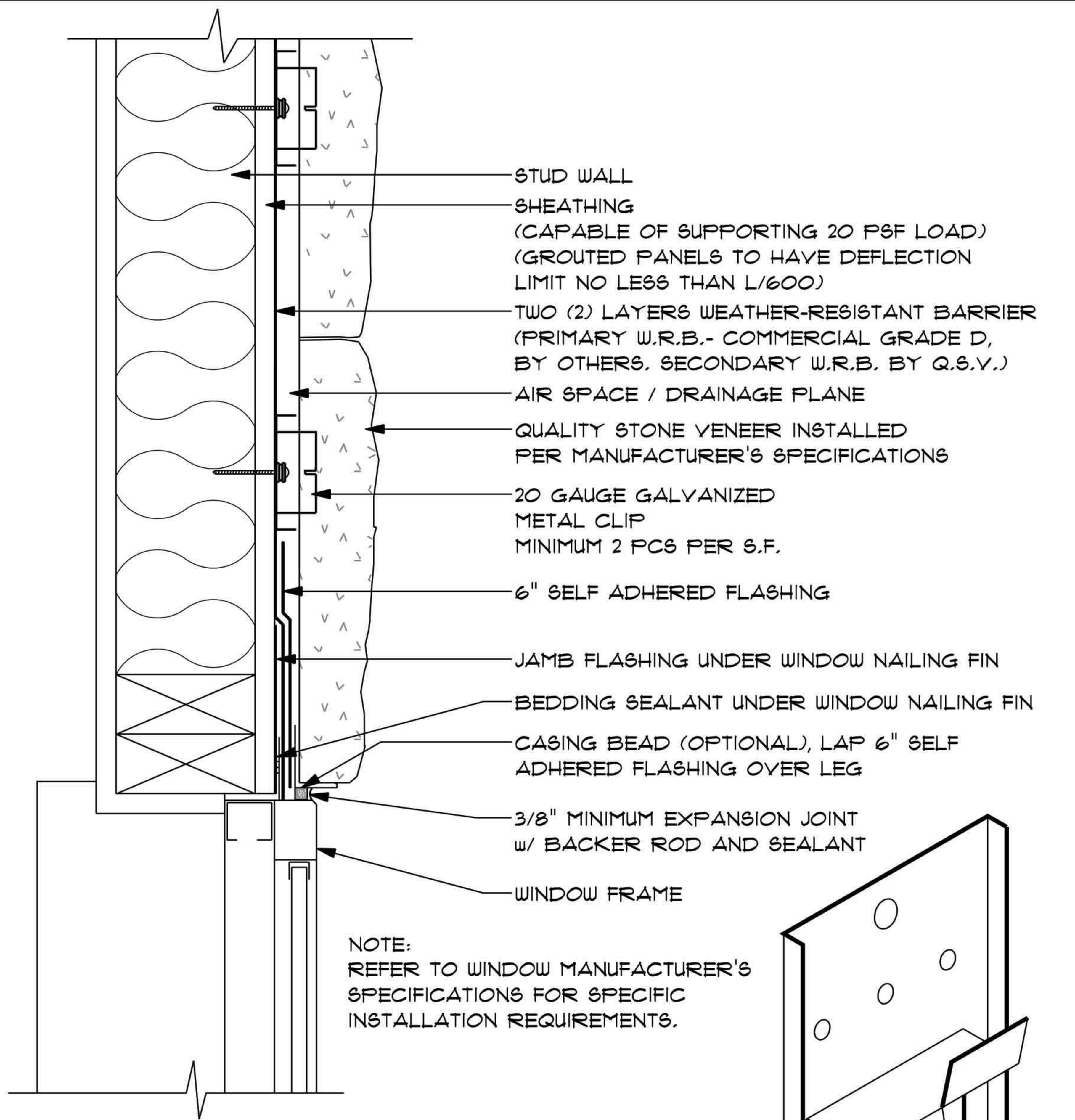

PLAN VIEW

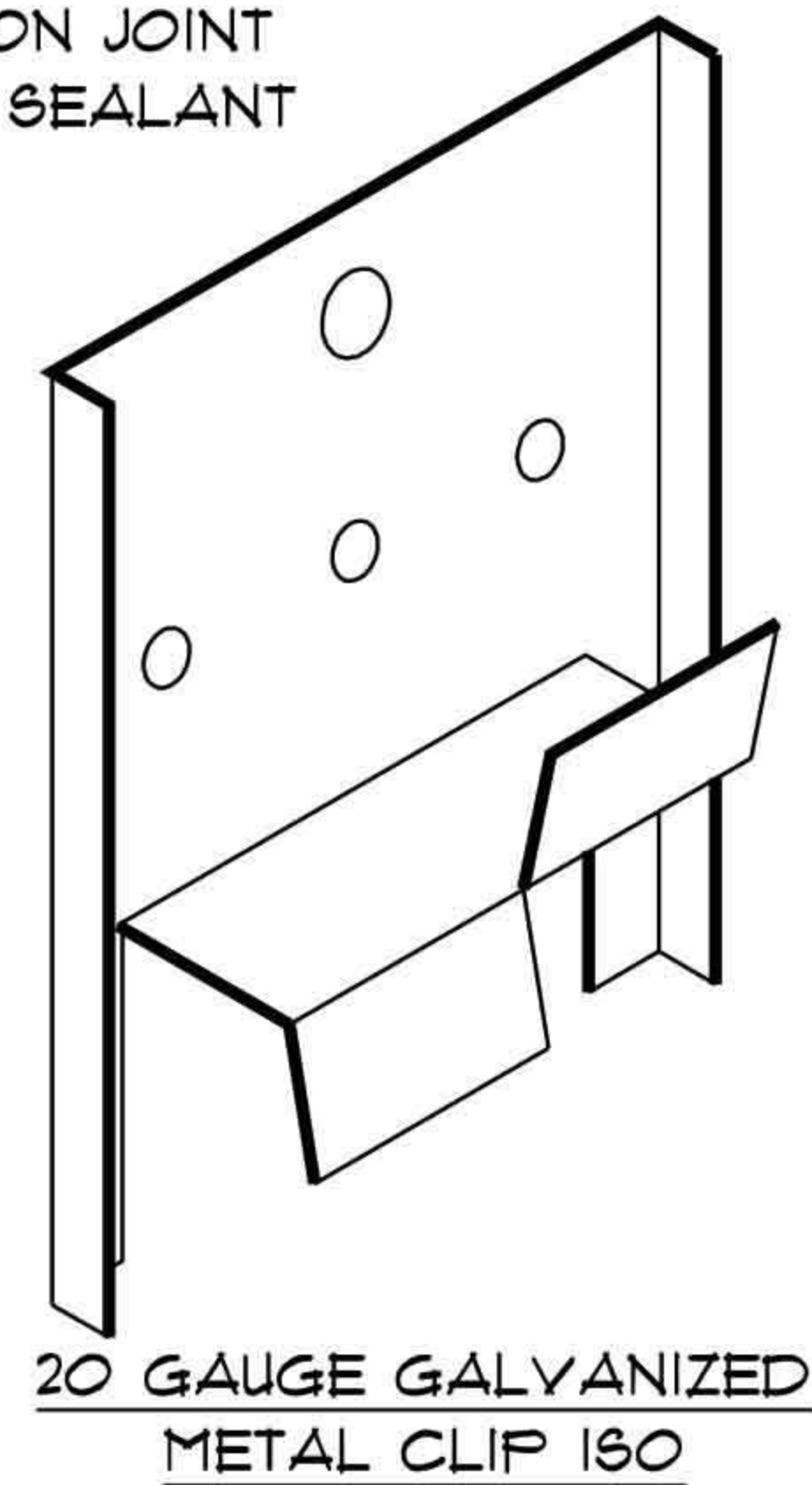

Rev. 8/18/2020

QSV-36.0

SCALE: 3" = 1'-0"

SIDE OF WINDOW DETAIL
WITH MANUFACTURED STONE
CLIP SYSTEM

QUALITY STONE VENEER

PHONE: 1-800-795-3229
FAX: 717-786-4038

WWW.QUALITYSTONEVENEER.COM



est. 1976

LAMBRIS PRODUCT LINE COLOR SELECTIONS

RECOMMENDED COLORWAYS BY STYLE & MORTAR PAIRING

LAMBRIS PRODUCT LINE:

Pair the letter the product falls under to the corresponding color packages list on the right.

Colorways with an asterisk are subject to upcharge.

A.
OHIO DRystack LAMBRIS
DRystack LAMBRIS
COBBLESTONE LAMBRIS
FIELDSTONE LAMBRIS

B.
METROPOLITAN BRICK
HISTORIC BRICK

C.
PIEDRA CORTADA
SIOTA BLOCK

D.
APILADA
SEGOVIA
URBANA FUSION
URBANA TRAVERTINE

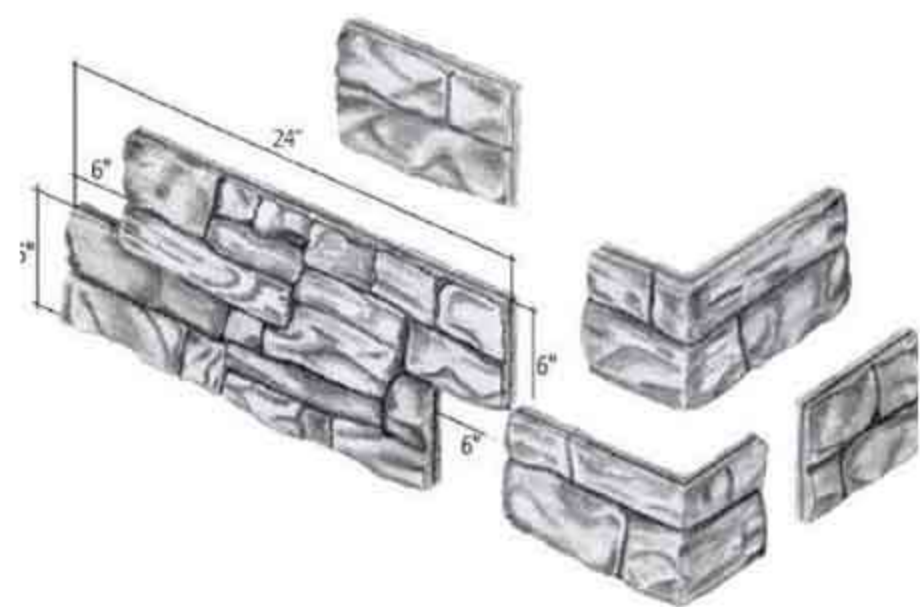



IBC 2021 DRAINAGE PLANE REQUIREMENTS

The newly updated 2021 version of the IBC (International Building Code) in regards to exterior cladding underlayment present new requirements for integration of a 3/16" minimum depth drainage plane between the Water Resistive Barrier and Stone Product.

THE STONE LEDGER

What does this mean?
To put it simply, while installing a stone veneer system in specific regions of the country the IBC specifies, incorporating an open drainage plane between the wall and the stone product is now a 2021 code requirement. Not only is this practice recommended nationally across the board, it is now stated as a necessity to include in certain areas.



01

LIGHT
COASTAL, CATAWBA, *EGGSHELL

TAN/BROWN
NEW ENGLAND,
SUSQUEHANNA,
POWDER RIDGE, IREDELL,
PROVENCE, WOODLAND, LURAY

GRAY/NEUTRAL
PA LIME, BULL RUN, GRANITE,
PINEHILLS, CONESTOGA

DARK
***ONYX**

A

LIGHT
***EGGSHELL**

RED/ORANGE/BURGUNDY
AMBER, BRACKSTON,
BRANDYWINE,
DUNRITE, HERITAGE,
PLYMOUTH, STATESMAN

GRAY/NEUTRAL
SLATE, UMBER

DARK
***ONYX**

B

LIGHT
CALACATTA

TAN/BROWN
SIENNA

GRAY/NEUTRAL
PEWTER

DARK
***ONYX**

C

LIGHT
***EGGSHELL**

TAN/BROWN
HAZEL, PUEBLO, SIENNA

GRAY/NEUTRAL
GRAHAM, OXFORD

DARK
***ONYX**

D

MORTAR COLOR PAIRING RECOMMENDATIONS FOR GROUTING	
MORTAR COLOR	LAMBRIS COLOR PACKAGE
Gray	Gray/Neutral
*Charcoal	Dark
*White	Light
*Buff	Tan/Brown

The 2021 IBC (International Building Code) states new requirement for inclusion of a Drainage Plane behind stone veneer systems.

The newly updated 2021 version of the IBC (International Building Code) in regards to exterior cladding underlayment present new requirements for integration of a 3/16" minimum depth drainage plane between the WRB and Stone Product.





©2022 QUALITY STONE VENEER, INC.

V3010522



QUALITY STONE VENEER, INC.

CLIP SYSTEM™ INSTALLATION GUIDE

ONE MANUFACTURER.
ONE INSTALLER.
ONE SOURCE OF ACCOUNTABILITY.



info@qualitystoneveneer.com
stoneonly@qualitystoneveneer.com

www.QualityStoneVeneer.com



ADMINISTRATIVE OFFICE

50 Refton Road
Refton, PA 17568
United States

Toll Free: (800) 795 3229
Direct: (717) 786 3229

REGIONAL

NORTH EAST
Tower City, PA
(717) 647-8550

Thompsontown, PA
(717) 535-5500

Hopkinton, MA
(508) 581-4115

MID ATLANTIC
Kearneysville, WV
(304) 260-0093

MID WEST
Portersville, PA
(724) 368-3790

SOUTH EAST
 Mooresville, NC
(704) 660-9418

Benson, NC
(919) 207-3839

WEST
Littleton, CO
(303) 791-6200